

Development of a V/f Control scheme for controlling the Induction motor- both Open Loop and Closed Loop using MATLAB.

Mr. Pramod Kondibarao Hingmire , Mr.Santhosh Kumar Rayarao

ME (EPS) Student¹ in MSSCET,JALNA,INDIA₁

Asst.Prof² in MSSCET,JALNA,INDIA₂

ABSTRACT

This paper presents design and implementation of scalar control of induction motor. This method leads to be able to adjust the speed of the motor by control the frequency and amplitude of the stator voltage of induction motor, the ratio of stator voltage to frequency should be kept constant, which is called as V/F or scalar control of induction motor drive. This paper presents a comparative study of open loop and close loop V/F control induction motor. The V/F control is based on advent of stator voltage derivatives. Simulation is carried out in MATLAB/SIMULINK environment and results are compared for speed control of induction motor.

Keywords

Scalar control (V/F), Induction Motor (IM), Open loop V/F control, closed loop V/F control, PI controller.

1. INTRODUCTION

The V/F controlled drives parameters are independent, easy to implement and low cost but they are classified as inferior performance of electrical drives.[1] Scalar controlled drives give somewhat inferior performance than the other control schemes but they are the easy to implement. In V/F control methods, the stator voltage is adjusted in a part of the supply frequency, except for low and above base speeds. At low frequency operation the voltage drop across stator resistance must be taken into account. The simplest stator resistance compensation method consists of boosting the stator voltage to compensate the voltage drop across the stator resistance [5, 6]. However, it is not easy to determine the boost voltage as it is easy to get flux saturated [2, 3, 5, 6]. Alternatives to the simple

boost voltage are described in [6]-[3]. However these methods need machine parameters and are complicated [1, 3]. The open Loop V/F method always suffers from oscillations especially under light load conditions [1, 9, 5, 8]. Many studies in relation to this instability problem have been carried out [7]-[8].However, faster strides in the development of DC Motors made it overtake Induction Motors when it came to usage in the industry or in transportation. The latter again made a comeback in 1985 with the development of Power Electronics-based drives, especially IGBT-based PWM Inverters for efficient frequency-changing. The following are some of the recent developments in Induction Motor drives:

- i. Better analytical models for design and research purposes
- ii. Better magnetic and insulation materials and cooling systems.
- iii. Availability of design optimization tools.
- iv. IGBT-based PWM Inverters for efficient frequency changing with low losses and high power density.
- v. New and better methods for manufacturing and testing.
- vi. High speed and high power applications.

With a widespread presence in all kinds of industries, households and in transportation, the Induction Motor is now called the „Racehorse of the Industry“.

2. OPEN LOOP V/F CONTROL

The open loop V/F control of an induction motor is the most common method of speed control because of its simplicity and these types of motors are widely used in industry. Traditionally, induction motors have been used with open loop 50Hz power supplies for constant speed applications. For adjustable speed drive applications, frequency control is natural. However, voltage is required to be proportional to frequency so that the stator flux

remains constant if the stator resistance is neglected. The power circuit consists of a diode rectifier with a single or three-phase ac supply, filter and PWM voltage-fed inverter. Ideally no feedback signals are required for this control scheme.

The PWM converter is merged with the inverter block. Some problems encountered in the operation of this open loop drive are the following:

- The speed of the motor cannot be controlled precisely, because the rotor speed will be slightly less than the synchronous speed and that in this scheme the stator frequency and hence the synchronous speed is the only control variable.
- The slip speed, being the difference between the synchronous speed and the electrical rotor speed, cannot be maintained, as the rotor speed is not measured in this scheme. This can lead to operation in the unstable region of the torque-speed characteristics.
- The effect of the above can make the stator currents exceed the rated current by a large amount thus endangering the inverter-converter combination.

These problems are to be suppress by having an outer loop in the induction motor drive, in which the actual rotor speed is compared with its commanded value, and the error is processed through a controller usually a PI controller and a limiter is used to obtain the slip-speed command.

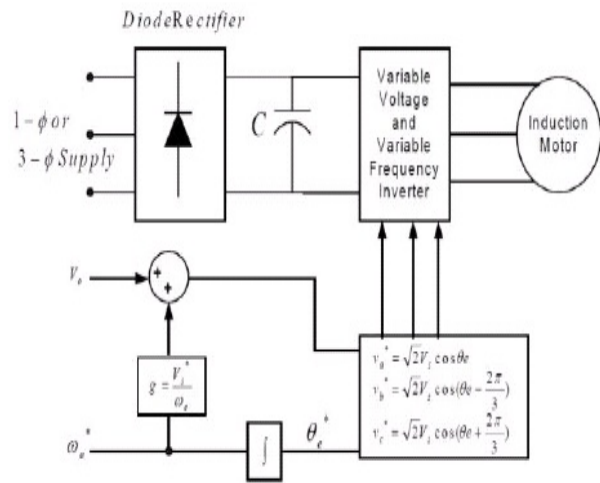

Fig-1: Block diagram of the open loop V/F control for an IM.

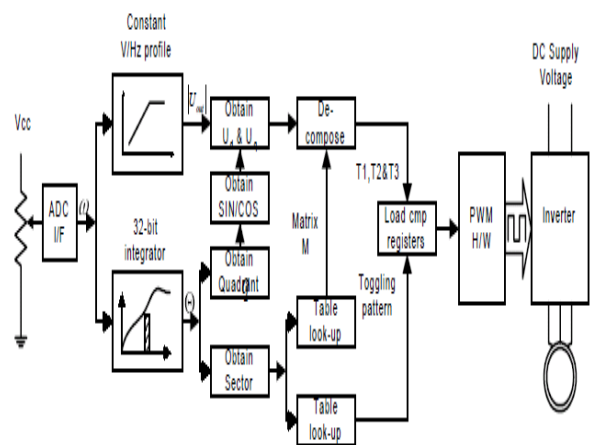

Fig-2: Block diagram of the open loop V/F control for an IM.

Table:1
Asymmetric and symmetric PWM resolution

	Asymmetric PWM	Symmetric PWM
PWM freq	24KHz	24KHz
PWM resolution	50nS	100nS
Effective resolution	10 bits	9 bits

3. CLOSED LOOP V/F CONTROL

The basis of constant V/F speed control of induction motor is to apply a variable magnitude and variable frequency voltage to the motor. Both

the voltage source inverter and current source inverters are used in adjustable speed ac drives. The following block diagram shows the closed loop V/F control using a VSI.

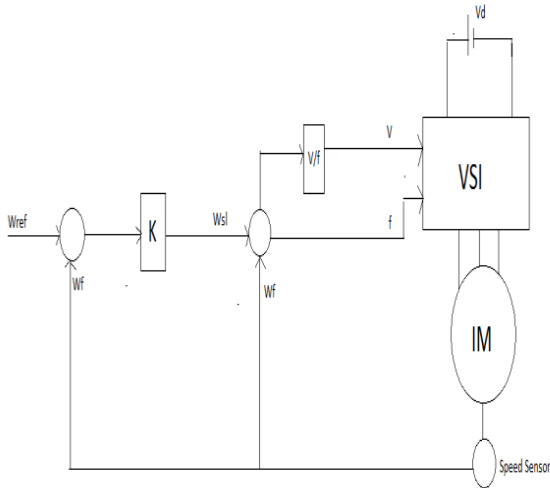

Fig-2: Block diagram for closed loop V/F control for an IM

A speed sensor or a shaft position encoder is used to obtain the actual speed of the motor. It is then compared to a reference speed. The difference between the two generates an error and the error so obtained is processed in a Proportional controller and its output sets the inverter frequency. The synchronous speed, obtained by adding actual speed and the slip speed, determines the inverter frequency. The reference signal for the closed-loop control of the machine terminal voltage is generated from frequency.

4. MATLAB SIMULATION OF OPEN LOOP V/F CONTROL

A SIMULINK block was created to analyze the open loop constant V/F control method using PI controller and the Stator current (Figure 3) and Electromagnetic torque (Figure 4) were plotted against time. The SIMULINK block is given below followed by the outcomes.

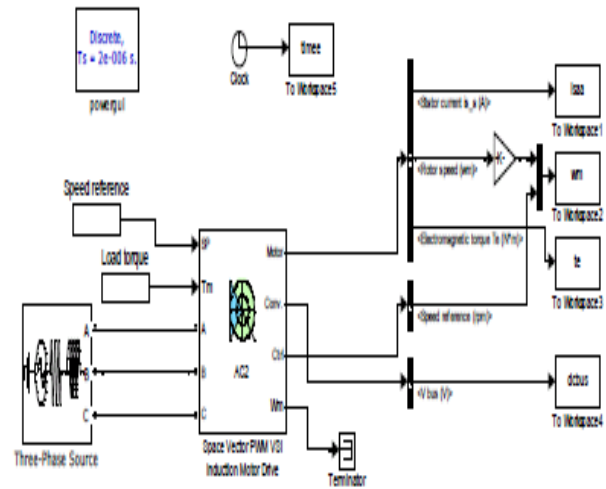

Fig 3: SIMULINK block of open loop constant V/F speed control using PI controller

5. CLOSED LOOP V/F SPEED CONTROL METHOD USING PI CONTROLLER

A SIMULINK block was created to analyze the close loop constant V/F control method using PI controller and the Stator current (Figure 7), and Electromagnetic torque (Figure 8) were plotted against time. The SIMULINK block is given below followed by the outcomes

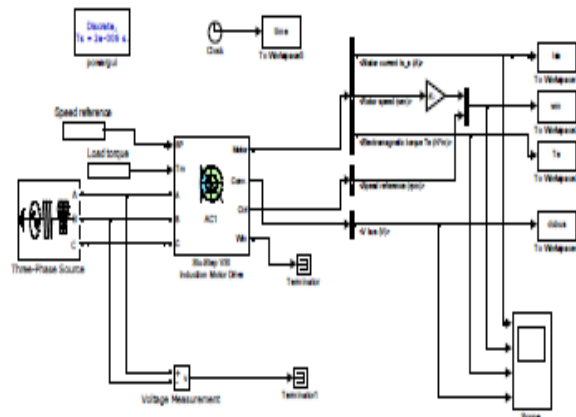

Fig 4: SIMULINK block of Close loop constant V/F speed control using PI controller

6. SIMULATION RESULTS

Experimental figures are presented in this section

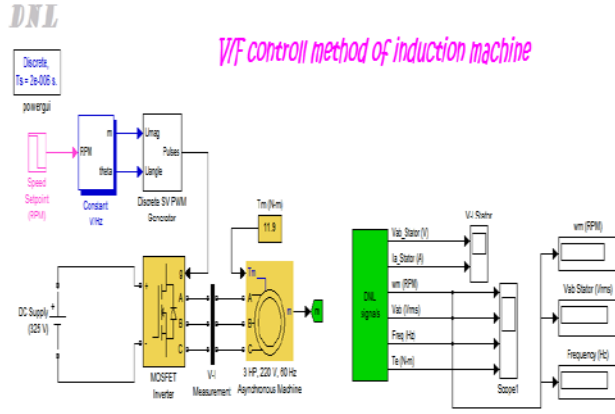

Fig: V/F control method for induction motor

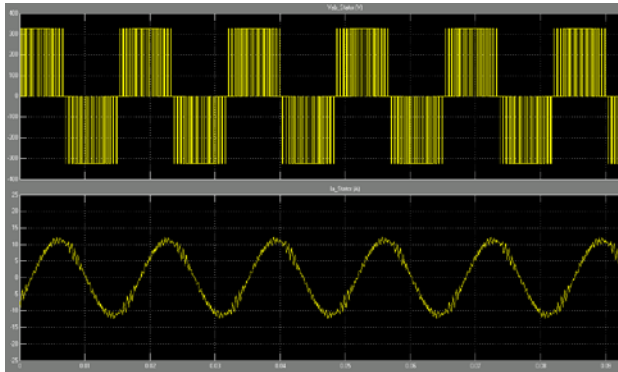

Fig: V-I of stator

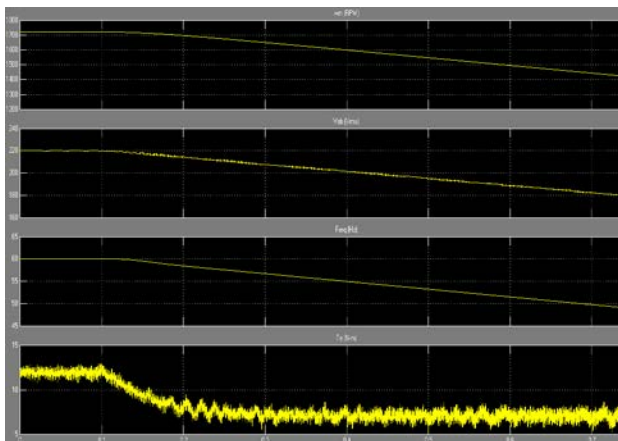
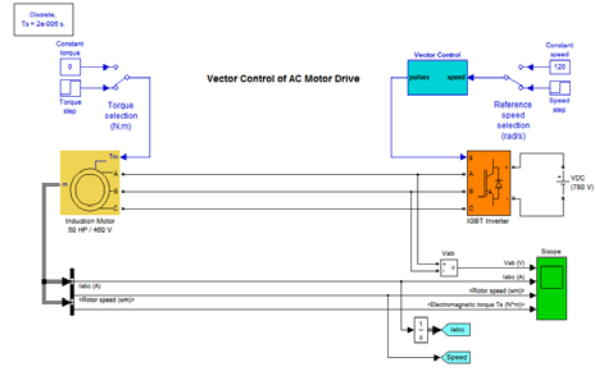

Fig: Speed, Torque, Voltage And Frequency



DNL

Fig: Vector Control Of AC Motor Drive(Proposed)

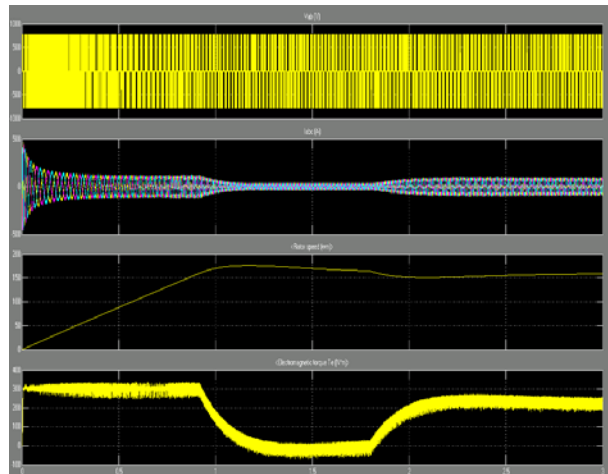

Fig: Outputs For Voltage Current, Speed And Torque

7. CONCLUSION

Simulation is carried out in MATLAB environment for speed control of induction motor for full load, using PI controller. And the results are checked. From the above experiment and results we concluded that the closed loop V/F control gives better response and better result as compared to open loop V/F control of induction motor.

8. REFERENCES

- [1] B.K. Bose, Power Electronics and AC Drives, Prentice- Hall, NJ, USA, 2002.
- [2] I. Boldea, "Control issues in adjustable speed drives, " IEEE Industrial Electronics Magazine, Vol. 2, No. 3, Sept. 2008, pp. 32 - 50.

- [3] A. Munoz-Garcia, T.A. Lipo, D.W. Novotny, "A new induction motor V/f control method capable of high-performance regulation at low speeds," Vol. 34, No. 4, July/August 1998, pp. 813 - 821.
- [4] H. Akroum, M. Kidouche, A. Aibeche, "A dSPACE DSP Control Platform for V/F Controlled Induction Motor Drive and Parameters Identification," Lecture Notes in Electrical Engineering (LNEE), vol. 121, pp. 305-312, 2011.
- [5] A. Oteafy, J. Chiasson, "A Study of the Lyapunov Stability of an Open- Loop Induction Machine IEEE Transactions on Control Systems Technology," Vol. 18 , No. 6, Nov. 2010, pp. 1469 – 1476
- [6] Wei Chen ; Dianguo Xu ; Rongfeng Yang ; Yong Yu ; Zhuang Xu "A novel stator voltage oriented V/F control method capable of high output torque at low speed," International Conference on Power Electronics and Drive Systems, PEDS2009, 2-5 Nov. 2009, pp 228 - 233.
- [7] C.J. Francis, H. Zelaya De La Parra, "Stator resistance voltage-drop compensation for open-loop AC drives," Electric Power Applications, IEE Proceedings, Vol. 144 , No. 1, January 1997, pp.21 - 26.
- [8] Y. Q. Xiang, "Instability compensation of V/Hz PWM inverter-fed induction motor drives," in Conf. Rec. IEEE IAS Annu. Meeting, vol. 1, Oct. 1997, pp. 613-620.
- [9] A. M. Trzynadlowski, Control of Induction Motors. Academic Press, CA, USA, 2001.



Author 1: Mr. Pramod Kondibarao Hingmire is pursuing his Masters degree in Electrical power system from mathsyodhari shikshan sanstha's college of engineering and technology jalna. He received his Bachelor's degree in Electrical Electronic & Power Engineering form Government College Of Engineering Aurarangabad
EMAIL: pramod.hingmire84@gmail.com



Author2: Mr.Santhosh Kumar Rayarao, working as Asst Professor in mathsyodhari shikshan sansthas college of engineering and technology jalna. He received his masters degree in Electrical power system , from jntu university Hyderabad, and his Bachelor's degree in Electrical and electronic engineering form jntu university Hyderabad.
EMAIL: santhu.

ACKNOWLEDGEMENT

I am greatly indebted forever to my guide, to my HOD and all teaching and Non teaching staff those who support directly and indirectly to complete my project in time. I sincerely thank to my Principal for their continuous encouragement and active interest in my progress that they gave throughout the work.

Iam grateful to Have my Masters degree (EPS) from **Mathshyodhsri shikshan sanstha's** collage of engineering and technology. JALNA, MAHARASTRA.