

MICRO CONTROLLER BASED REGULATED POWER ASSESS CONTROL FOR ELECTRONIC APPLIANCES

Akinmuyisitan T. M. and Dr. K. Obahiagbon
Department of Mathematics and Computer Science,
Benson Idahosa University

ABSTRACT

Access control systems are electronic systems that use a code, card, device biological characteristics of an individual as the basis for determining authorization to enter or exit a facility or an area within a facility. It is meant to protect intruders from general access to large volume of data in a computer system, and to protect other electronic appliances from unauthorized users. It was developed with locally sourced components, invariably recycling of wasted or dead electronic devices. The software was developed with C++ programming language which is user's friendly and modification could be made from time to time and when necessary. The device worked as designed and was able to power and shut down a system unit or light bulb with the appropriate code. It can withstand a 220/240v, 50Hz power supply. The device is user's friendly and can be introduced as a unit into the already designed power packs of existing electronic system.

INTRODUCTION

Advances in sciences, communication technologies present new opportunities for users to increase productivity, reduce cost, facilitate innovation and create virtual collaborative environments for addressing new challenges.

In many systems (industrial or domestic), there exist inherent security risks of unauthorized access or user of the product. To fulfill such security and privacy needs in various applications, encryption and general security of data, products, and item is very important to minimize malicious attacks from unauthorized parties and to safeguard sensitive data, services and products.

An electronic system is no more secured than the human systems responsible for its operation. Malicious individuals have regularly penetrated well designed electronic products by taking advantage of the carelessly available power switches. This short fall often lead to frequent breakdown of equipment, data integrity compromise, and loss of lives in severe cases.

It is investigated that the power units of most electronic systems at homes, offices and industries are not properly protected and adequately secured. Switches controlling electronic power units

are opened to all and sundry. Intruders find it easy to switch on /off computer system and other electronic devices whenever and anytime they are in contact with them. This pitfall makes it possible for unauthorized users to access and pose damage to products and services.

This paper reports the design and construction of a scalable, fault tolerant micro controller based power access control system that provides an application for users to enter valid pass word in order to access or shut down electronic and telecommunication equipment. This design was tested, deployable and found to be very efficient. It is already in use in the Radio/Television studio and digital laboratory of Benson Idahosa University, Benin City, Nigeria where it was purposefully designed.

Applications

The micro controller based power regulated system discuss in this paper has wide applications both in domestic and industrial electronic appliances. The system helps to enhance electronic/electrical system privacy and security .It could also be integrated into the power pack of a computer system units and telecommunication equipment. Also, in videography and lithography, in hospital theater to control light dimmers where maximum light control is needed.

Material and Method

Electronic security is crucial in almost any home and technology-driven industries. It is an integral part of maintaining an operational industry. The main objective of the system is to take advantage of the power source to control all processes and mechanisms by which electronic system, information and services are protected from unintended or unauthorized access, change or destruction. It also guides against unplanned events. This is achieved by ensuring only an authorized user with valid codes accesses an electronic system. The brain behind this design is the Microcontroller.

ATMEL 8952 (AT89C52) Microcontroller

The AT89C52 is a low-power, high-performance CMOS 8-bit microcomputer with 8K bytes of flash programmable and erasable read only memory (PEROM). The device is manufactured using Atmel's high-density non-volatile memory technology and is compatible with the industry-standard 8051 and 80C52 instruction set and pin-out.

The on-chip flash allows the program memory to be reprogrammed in-system or by a conventional non-volatile memory programmer. By combining a versatile 8-bit CPU with flash on a monolithic chip, the Atmel AT89C52 is a powerful microcomputer which provides a highly-flexible and cost-effective solution to many embedded control applications.

The AT89C52 provides the following standard features: 8K bytes of Flash, 256 bytes of RAM, 32 I/O lines, three 16-bit timer/counters, a six-vector two-level interrupt architecture, a full-

duplex serial port, on-chip oscillator, and clock circuitry. In addition, the AT89C52 is designed with static logic for operation down to zero frequency and supports two software selectable power saving modes. The Idle Mode stops the CPU while allowing the RAM, timer/counters, serial port, and interrupt system to continue functioning. The Power-down mode saves the RAM contents but freezes the oscillator, disabling all other chip functions until the next hardware reset.

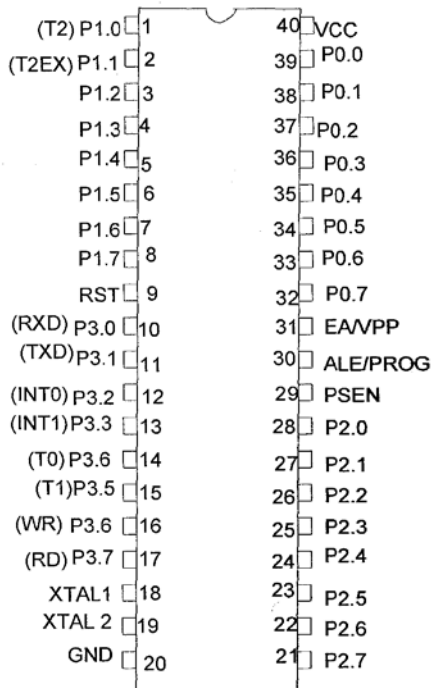

Fig 1: The AT89C52 chip

2.7.1. Pin Description

VCC - Supply voltage.

GND - Ground

Port 0

Port 0 is an 8-bit open drain bi-directional I/O port. As an output port, each pin can sink eight TTL inputs. When 1s are written to port 0 pins, the pins can be used as high impedance inputs. Port 0 can also be configured to be the multiplexed low order address/data bus during accesses to external program and data memory.

Port 1

Port 1 is an 8-bit hi-directional I/O port with internal pull ups. The Port 1 output buffers can sink/source four TTL inputs. When 1s are written to Port 1 pins, they are pulled high by the internal pull-ups and can be used as inputs. As inputs, Port 1 pins that are externally being pulled

low will source current (IIL) because of the internal pull-ups. Port 1 also receives the low-order address bytes during Flash programming and verification.

Port 2

Port 2 is an 8-bit hi-directional I/O port with internal pul-lups. The Port 2 output buffers can sink/source four TTL inputs. When 1s are written to Port 2 pins, they are pulled high by the internal pull-ups and can be used as inputs. As inputs,

Port 2 pins that are externally being pulled low will source current (IIL) because of the internal pull-ups. During accesses to external data memory that uses 8-bit addresses (MOVX @ RI), Port 2 emits the contents of the P2 Special Function Register.

Port 2 also receives the high-order address bits and some control signals during Flash programming and verification.

Port 3

Port 3 is an 8-bit hi-directional I/O port with internal pull-ups. The Port 3 output buffers can sink/source four TTL inputs. When 1s are written to Port 3 pins, they are pulled high by the internal pull ups and can be used as inputs. As inputs, Port 3 pins that are externally being pulled low will source current (IIL) because of the pull-ups.

RST

Reset input. A high on this pin for two machine cycles while the oscillator is running resets the device.

ALE/PROG

Address Latch Enable is an output pulse for latching the low byte of the address during accesses to external memory. This pin is also the program pulse input (PROG) during Flash programming.

PSEN

Program store Enable is the read strobe to external program memory. When the AT89C5I is executing code from external program memory, PSEN is activated twice each machine cycle, except that two PSEN activations are skipped during each access to external data memory.

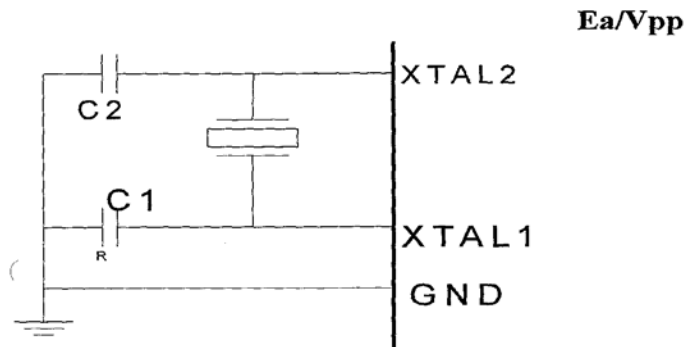

Fig 2: Crystal Oscillator Circuitry

External Access Enable (EA): must be strapped to GND in order to enable the device to fetch code from an external memory locations starting at 0000H up to FFFFH. But it should be noted that if lock bit 1 is programmed, EA will be internally latched on reset.

EA should be strapped to Vcc for internal program executions.

XTAL 1 is the input to the inverting oscillator amplifier and the input to the internal clock operating circuit.

XTAL 2 is the output from the inverting oscillator amplifier.

Idle Mode

In idle mode, the CPU puts itself to sleep while all the on-chip peripherals remain active. The mode is invoked by the software. The content of the on-chip RAM and all the special function register remain unchanged during this mode. The idle mode is terminated by any enabled interrupt or by a hardware reset.

Power-down Mode

In the power down mode the oscillator is stopped and the instruction that that invokes power-down is the last instruction executed. The on-chip RAM and Special Function Registers retain their values until the power-down mode is terminated the only exit from the power-down mode is the hardware reset. The reset redefines the SFRs but does not change the on-chip RAM. The reset should not be activated before Vcc is restored to its normal operating level and must be held active long enough to allow the oscillator to restart and stabilize.

Program Memory Lock Bits

On the chip are three lock bits which can be left unprogrammed (U) or can be programmed (P) to obtain the additional features.

Programming the Flash

The AT89c5 1 is normally shipped with the on-chip flash memory in the erased state (that is, contents =FFH) and to be programmed. The programming interface accepts either a high voltage (5 Volts) or a low voltage (Vcc) program enable signal.

PROGRAMING ALGORITHM

The following steps are always taken to program the ATX89C51.

1. Input the desired memory location on the address lines.
2. Input the appropriate data byte on the data lines.
3. Activate the correct combination of control signals.

Raise EA/Vpp to 5V for the high voltage programming mode

Operations of Microcontroller Based Power Regulated System

The system came up as a result of diligent researches from journal materials, relevant textbooks, observations and questioning. The system meticulously undergone different stages involved in system development life cycle. It provides absolute protection and security against some forms of disturbances. For better understanding, it shall be subdivided into three parts:

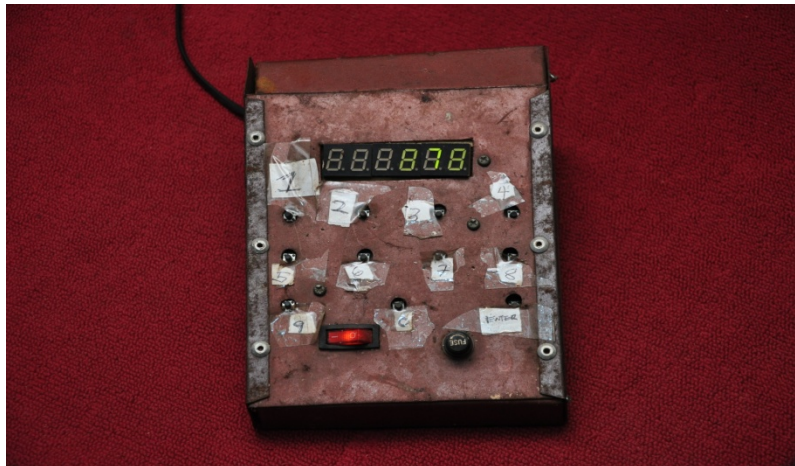

Fig. 3: Micro Controller Power Access Control
Source: Benson Idahosa University Studio, Nigeria.

1. Power supply unit
2. Display unit
3. Switching unit

When the system is switched on, “enter pin code” is displayed on the LCI). User enters password via the keypads which interface the microconflol1er. Pins 20, 40 are power pins of the

microcontroller. Pin 40 is connected to 5v (logic 1) and pin 20 to the ground (logic 0). As each key is pressed, the processor saves the entered keys in a register. Once enter key is pressed, the processor analyze the entered code stored in the register and compare with the saved code in another register. If the codes are the same, P1.2 will be high (logic) 1 and the 5v pin invariably closes the relay unit thereafter , allow power from the mains to the output If incorrect codes are entered, “invalid codes “is displayed o the LED. Shut down code is also entered accordingly to switch off output. System is thereby, a clear substitution for mechanical switch in the existing system if engaged.

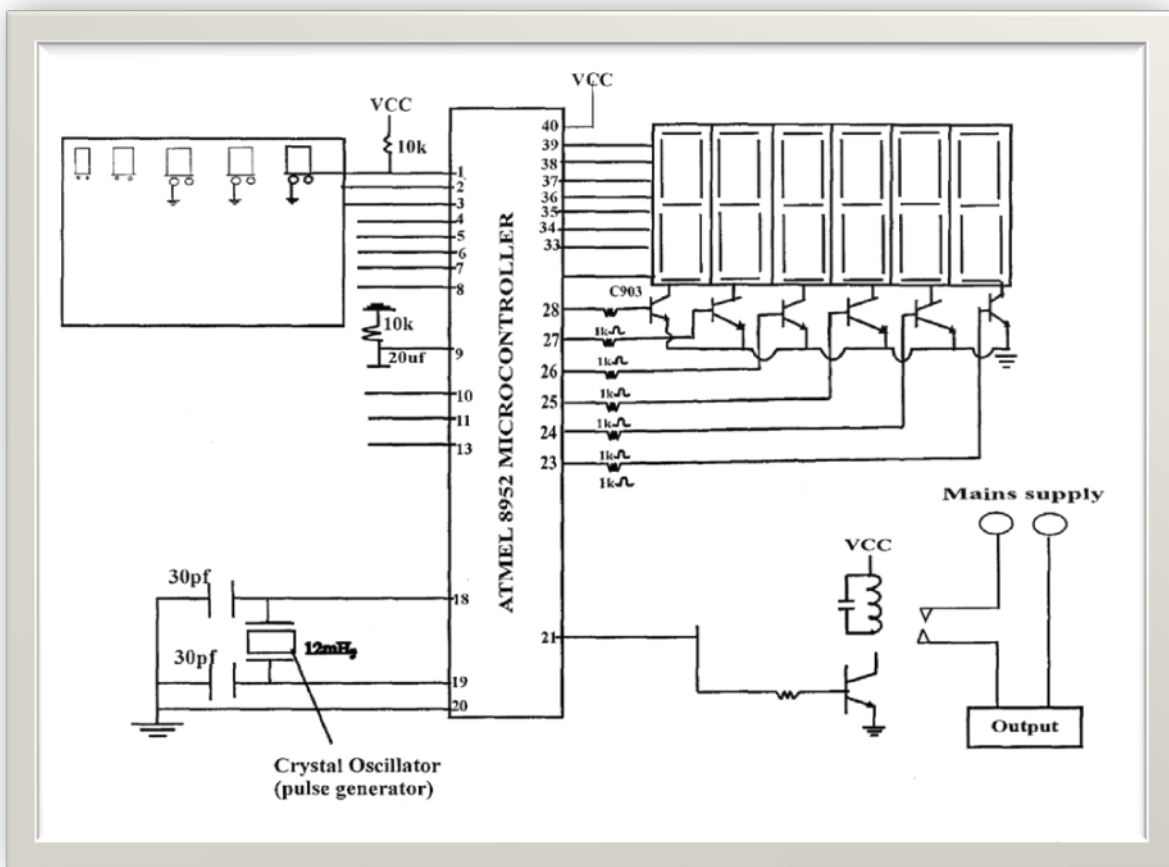

Fig. 4: Circuitry of Power Access Control

3.5. Design of the Power Supply Unit

The power supply unit performs the function of converting an AC source to a DC power which is needed to power the load section of the circuit. The power supply unit design involves the use of a step down transformer, a rectifier circuit, a capacitor filter and a voltage regulator.

3.5.1 DC parameters of the circuit

For the design of the circuit, the following dc parameters were required

1. DC current rating of the circuit = 500mA
2. DC voltage rating of the circuit 5V
3. Ripple factor of the power supply unit = 0.2V

3.5.2 Transformer

The transformer used in this design was sourced locally from an electronic shop. It is a step down transformer having a rating of 240V, 500mA as shown in fig 3.1. The transformer converts the mains 220 - 240V to a voltage of 12V. Its job is to step down the AC supply voltage to suit the requirement of the circuits. It also provides isolation from the supply line, an important safety consideration.

220/ 240V, 50Hz.

12 V AC

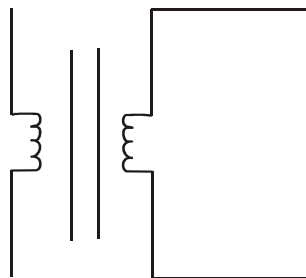

Fig 5: Schematic Diagram of 12 volts, 500mA step down transformer

3.5.3 Rectifier circuit

The type of rectifier used in the project was the full-wave bridge rectifier of the 1N4007 x 6 series.

In the rectifier circuit, the alternating voltage available at the secondary winding of the transformer is converted to pulsating dc due to the clapping and clipping action of the diode rectifying circuit.

The peak voltage of the ac rectified voltage is given as:

$$\begin{aligned}
 \text{Dc (out)} &= V_{\text{rms}}\sqrt{2} \\
 &= 12\sqrt{2} \\
 &= 16.9
 \end{aligned}$$

$$V_p = 16.9V$$

3.5.3.1 Peak Inverse Voltage (PIV) of the Diode

The full-wave rectifying circuit PIV is defined as the maximum voltage that occurs across the rectifying diode in the reverse direction. For the full wave bridge rectifier employed in the project, the PIV rating of the diode should be about 1.5 times the peak voltage of the ac rectified voltage i.e.

$$\begin{aligned} \text{PIV} &= 1.5 \times V_{\text{rms}} \sqrt{2} \\ &= 1.5 \times 12 \sqrt{2} \\ &= 25.455 \text{ volts} \approx 25V \end{aligned}$$

The IN4001 was selected since the PIV specified for it by the manufacturer is 1000V which is greater than 26V.

3.5.4 Filter Circuit

The function of this circuit element is to remove the fluctuation or pulsation present in the output voltage supplied by the rectifier. A capacitor filter was employed.

3.5.4.1. Choice of Filter Capacitor

The capacitor was chosen in such that its voltage rating is not less than 2.5 of the supply voltage.

Therefore, since the supply voltage is 12V, the minimum voltage of the capacitor will be as follows.

3.5.4.2 Capacitance Rating

From the approximate ripple voltage formula

$$V_R = \frac{I_o}{2FC}$$

$$C = \frac{I_o}{2FV_R}$$

Where F = main frequency = 50Hz

I_o = DC element from regulator = 500mA

C = capacitance

V_R = Ripple voltage 45% of V_{dc} , where 45% is the ripple factor.

$V_R = 45\% \times 12 = 5.4$

$$C = \frac{I_o}{2FV_R}$$

$$C = \frac{0.5}{2 \times 50 \times 5.4} = 9.25 \times 10^{-4}$$

Hence 1000 μ F was used and its rating is 35v.

3.5.5. The Voltage Regulator

The type of voltage regulator employed in this project is the fixed regulator type 78xx series as shown in fig 3.2. They have an internal voltage of 3volts and a maximum current of 500mA. Since the operation of the circuit required a supply of 5V, the 7805 was made use of.

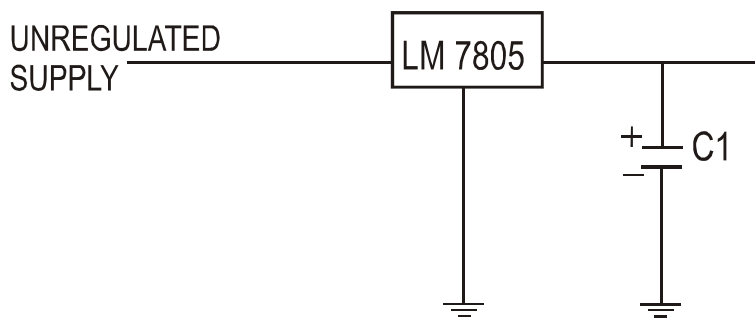

Fig 6: Constant 05 volts circuit using LM7805

3.6 Design of the Display Unit

The display unit is made up of four 7- segment displays each connected in the common anode arrangement as shown in fig 3.3. The choice of the 7- segment display lies in their good visibility.

The displays are all driven by the microcontroller. All the corresponding LED cathodes of each segment of the four 7-segment displays were connected together in parallel and each connected directly to port 0 of the microcontroller. The common anode lines from each of the displays were connected to the port 1 of the microcontroller via an NPN transistor and 1 K resistor. These lines are taken high for short period of the time to turn on the displays.

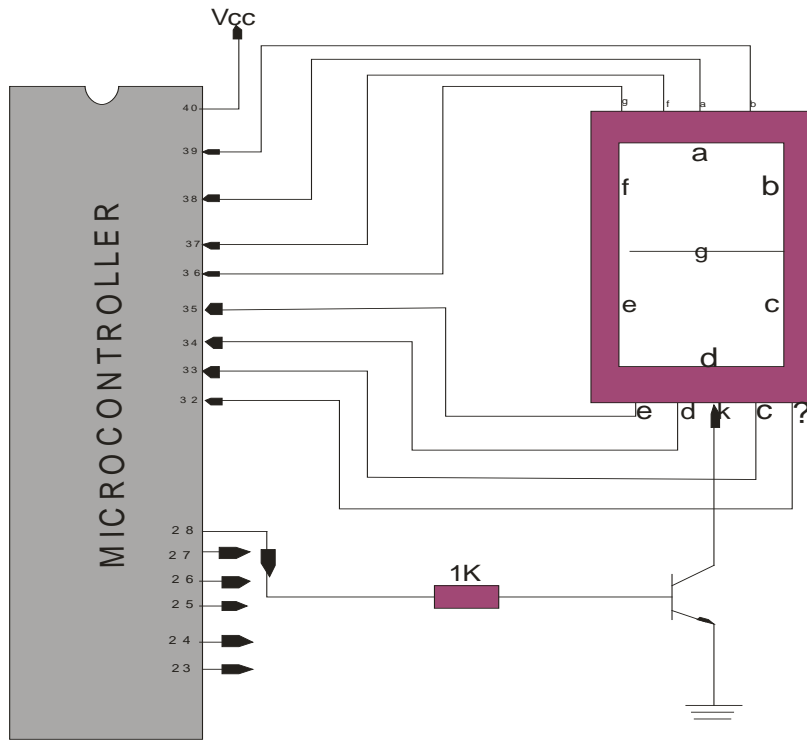

Fig 7: The diagram of 7-segment display interfacing a microcontroller

3.6.1 Display Calculation

Each segment of the 7- segment display is a LED with a voltage drop of 2V and consumes about 10mA. The decimal point power consumption is minimal and can be neglected in this calculation.

The maximum current consumed by the 7-segment display when the entire segments are lighted is $7 \times 10\text{mA} = 70\text{mA}$.

Since the LED runs on 2volts and the microcontroller uses 5V, it will not be advisable to pass the voltage from the microcontroller directly to the common anode of the display. This is no problem since the 7-segment display has an internal resistor which drops the voltage by 3V.

Since we know the supply voltage and the desired current and voltage, it is possible to calculate the value of this inbuilt resistor.

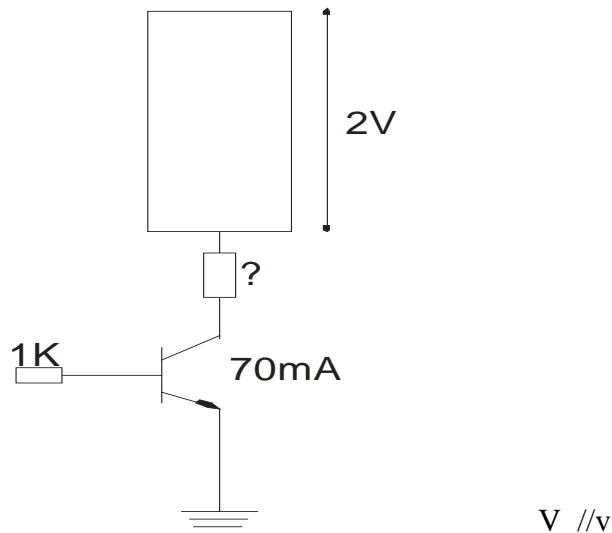

Fig 8: Display connection.

Supply voltage: $V_{cc} = 5V$

Voltage desired $V_{leds} = 2V$

Therefore,

$$V_r = 5V - 2V$$

$$V_r = 3V$$

Since the 10mA flows through each led,

From ohms law, $V=IR$

$$R = 3/0.1 = 300\Omega \text{ (this is the value of the inbuilt resistor)}$$

Since the microcontroller can source a maximum current of 10mA at 5V, there is a need to switch the 7-segment using a transistor.

3.6.2 Choice of transistor

First, since the 7-segment display is the common anode type, an NPN transistor will more appropriate. The other factors considered in the choice of transistor are I_{ce} and T_b at saturation. The V_{ce} at cut-off should be able to withstand the supply voltage which is 5V. In this case, the I_{ce} of the transistor must be greater than 70mA and the I_b must not exceed 10mA since that is the maximum the processor can source. Considering the above, the BC471 was chosen with the following properties.

$$V_{ceo} = 12V$$

$$\text{Max } I_c \text{ at saturation} = 170mA$$

$$V_{cc} \text{ at saturation} = 0.2V$$

$$V_{be} \text{ at saturation} = 0.7V$$

$$h_{fe} = 16$$

Base resistor R_b

We can calculate the value of R_b required driving the processor to saturation at an I_{ce} of 70mA.

$$h_{fe} = I_{ce}/I_b$$

Therefore, $I_b = I_{ce}/h_{fe}$;

Since, $I_{ce} = 70\text{ma}$, $h_{fe} = 16$

$$I_b = 70/16 = 4.37\text{mA}$$

$$\text{But } R_b = (V_{cc} - V_{bc})/I_b = 5 - 0.7/4.37 = 0.984\text{k}\Omega.$$

This is why it was used to ensure the transistor is driven to saturation.

3.7 Transistor Relay Driver

Two relays are connected to trigger the main supply. Its circuit configuration is as shown in fig 3.5

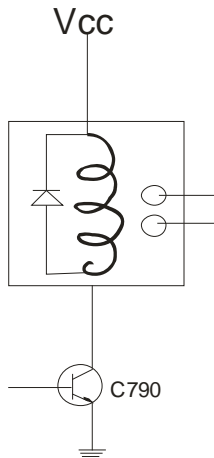

Fig 9: Transistor Relay Driver

3.7.1 Relay Parameter

Relay resistance = 100Ω

Relay voltage = 12volt

From ohm's law $V = IR$

$$I = V/R = 12/100$$

Relay current = 120mA

3.7.2. Choice of Transistor

Since relay requires a current of 120mA, this implies that the transistor's I_{ce} must be greater than 120mA. Also the base current, I_b must not exceed 10mA or else the transistor will sink the processor. Another important factor to consider is the transistors V_{ce0} , which should not be less than the supply voltage. If the transistor V_{ce0} is less than the supply voltage, collector-emitter gate of the transistor will collapse at cut off. Considering the above, C90 was chosen. Its properties are as follows:

$$V_{ce0} = 12V$$

$$\text{Max } I_c \text{ at saturation} = 160mA$$

$$V_{ce} \text{ at saturation} = 0.2v$$

$$V_{be} \text{ at saturation} = 0.7v$$

$$h_{fe} = 800$$

Base Resistor R_b :

The value of the base resistor required to limit the current can be calculated as:

$$h_{fe} = I_{ce} / I_b$$

Therefore; $I_b = I_{ce} / h_{fe}$,

$$I_{ce} = 120mA, h_{fe} = 800$$

Therefore; $I_b = 120/800 = 0.15mA$

$$I_b = 0.15mA$$

But $R_b = (V_{cc} - V_{be}) / I_b$

$$R_b = (5 - 0.7) / 0.15mA$$

$$R_b = 4.3 / 0.15mA$$

$$R_b = 28.6K$$

30K was used in the design.

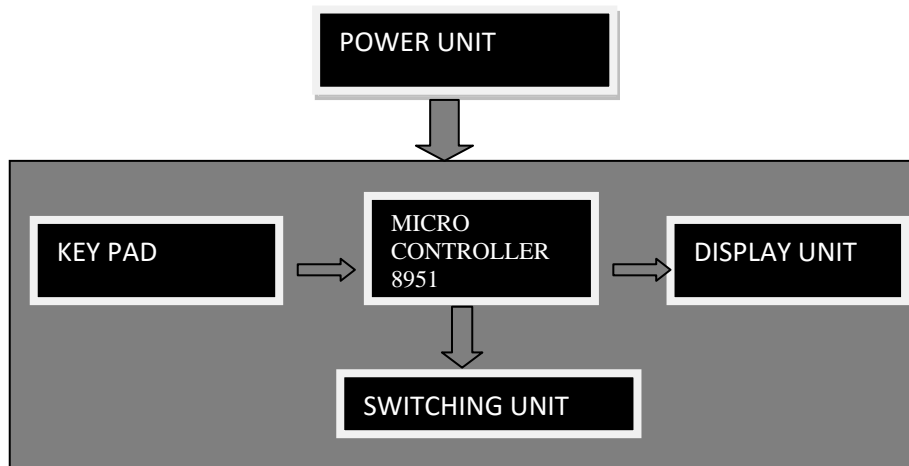

Fig.10: Block Diagram Micro Controller Power regulated unit

SYSTEM IMPLEMENTATION AND MAINTENANCE

This is the construction and the delivery of the system into the day to day business or organization operation. This part includes the mode of joining and all the steps taken in realizing the design. The tests carried out are discussed and the results stated.

4.1. Circuit Construction

The various components that make up the circuit were bought and the circuit was first constructed stage by stage on the breadboard and the necessary adjustments were made. After each stage had been certified okay, the system was transferred to a Vero board where the various components were soldered and also tested. Parts that were not required to be continuous were cut open by razor blades. Jumper wires were used to connect certain parts of the circuit which do not fall along the continuous line on the Vero board. The method of joining used in this project is soldering. Soldering is the joining of two materials together or the connection of components onto a Vero board using a soldering lead. Soldering iron is the main tool used in soldering and it is heated to a certain temperature so as to melt the lead used in the joining. All the component leads are joined to the Vero board by soldering and so also other connections in the construction.

The circuit was then arranged into the casing.

4.2. Casing and Assembling

This is an important aspect of the design work, it's the appearance given to the final work. After soldering on the Vero board, we do not leave it like that it has to be arranged in a case in such a way that looks attractive to the eye.

Metallic case was used in casing the work for the sake of rigidity. The dimension of the box was arrived at after considering various factors such as the width and length of the Vero board, transformer and also the circuit models. After considering all these factors the measurement below was arrived at height = 8.5cm, breadth 15cm and length = 20cm.

4.3. Software Development

This is the computer programming, documenting, and testing involved in creating and maintaining applications and frameworks involved in the production of software.

4.3.1. Programming Language

Assembly language was used to program the AT89C52 low-power; high-performance CMOS 8-bit microcomputer with 8K bytes of flash programmable and erasable read only memory (PEROM). C++ and other object oriented language could also be used. This is preferred to structured programming for implementation of object oriented design. It is quite flexible, users

friendly and provides graphical interface designs and numerical analysis. It is an event driven and general purpose programming language.

4.5 Hardware Testing and Results

After the construction of the circuit on bread board, testing was carried out to determine if the result obtained met the design parameter used. Testing was carried out in various stages as the entire circuit was built on models. The first model consists of the power supply circuit then the relay unit and finally the entire circuitry.

MODEL 1

Test was carried out on the power supply and the relay unit. The test results are shown below

Output voltage	Measured	Expected
From regulator		
7805	5.1v	5v

MODEL 2

Relay current	Measured	Expected
	120.3MA	120MA

4.6. Software Testing and Results

Software testing can be stated as the process of validating and verifying that a computer programme / application/product:

- i. Meets the requirement that guided its design and development,
- ii. Works as expected
- iii. Can it be implemented with the same characteristics?
- iv. And satisfies the needs of stakeholders

When wrong pin codes were issued, “incorrect pin code” was displayed on LCD and access was consequently denied to the output. For this frame work, 543210 is the correct pin code. At testing stage, this system accepted the code and lits a 40W bulb output. This implies that the software meets the above conditions.

5.2. Conclusion

This study was handled with utmost care with every stage serving as a reminder of all that has been taught and put into practice in science and engineering. The design of the system was a challenging effort and in fact an eye-opener into the world of microcontroller. It is however fulfilling seeing the kind of device that has been made and knowing the logic behind every design work.

REFERENCES

- Charles P.L (2012). Encyclopedia of Electronic Computer. 1st Edition. Volume 2: Marker Media Inc.
- Donald, P.L. (1975). Basic Electronic Circuit, Mc Graw-hill 2nd Edition.
- Gibson, T.R. (1982). Electronics Logic Circuits, 3rd Edition Edward Arnold, New York.
- Hughes, M. “Electrical and Electronic technology” Eight editions. Horowitz, P. “The Art of Electronics” Second Edition Cambridge University Press, Ibadan
- Miichael J. G. (2011). “How to Diagnose and fix Everything Electronics. Publisher: 1st Edition. McGraw-Hill.
- Onohaebi S.O. (1998). “Basic Electronics”, published by Mufti International Services, Second Edition, Benin city
- Paul S. (2013). “Practical Electronic for Inventors, 3rd Edition. Publisher: Tab Electronics.
- Paul, Horowhz and Winfield, Hill (2015). “The Art of Electronics”. 3rd Edition. Publisher: Cambridge University Press,
- Robert L. P. (2007). Electronic Access Control. Pp.1-17. Available at www.sciencedirect.com.
- Theraja, B.L., Theraja, A.K. (2002). “A textbook of Electrical Technology”, S. Chand and Company Ltd, Twenty-third edition.
- Tokheim, R.L. (2010) “Digital Electronics (McGraw Hill International) Student Edition, 1st Edition.