

Voltage Stability Improvement by using Fuzzy Logic Controller in Multi -Machine Power System

Prashant Das¹, Shailesh M Deshmukh², Lukesh Sahu³

Disha Institute of management and Technology Raipur^{1,2}
 NMDC DAV POLY Education City Geedam Dantewada(C.G.)³

Abstract— Voltage stability is one of the important issues in power system .Voltage sage, voltage swell and generation of harmonics that may cause system instability. To compensate all these problems in transmission system svc is used. Static VAR Compensator (SVC) has been used as a supplementary controller to improve transient stability and power oscillation damping of the system. The aim of svc with fuzzy logic controller is to make it more compatible with prevailing load demand so as to maintain the system stability under heavy load condition or light loading conditions. A static VAR compensator is chosen as a low cost solution to replace a conventional capacitor bank, thus allowing a continuous and flexible nodal voltage adjustment.

Keywords— FACTS, fuzzy logic, reactive power, SVC, voltage stability

I. INTRODUCTION

SVCs can be very effective in controlling voltage fluctuations at rapidly varying loads. Unfortunately, the price for such flexibility is high. Nevertheless, they are often the only cost-effective solution for many loads located in remote areas where the power system is weak. Much of the cost is in the power electronics on the TCR. Sometimes this can be reduced by using a number of capacitor steps. The TCR then need only be large enough to cover the reactive power gap between the capacitor stages. Most of a.c. appliance have induction motor as their main drive which works at lagging power factor and the mostly contribute for lagging power factor of system. SVC provides capacitive var which helps to improve the power factor and compensate reactive power demand.

The main objective of using static var compensator with supplementary controller is to improve the power factor in distribution system during normal as well as abnormal condition and also to improve the voltage stability of system during fault condition so that to meet continuity of supply. The ultimate objective of compensation is to increase transmittable power. This may required to improve the KW capacity of transformer and alternators, to improve

the regulation of line and to decrease overall cost per units. [3]

II. STATIC VAR COMPENSATOR

The SVC is a shunt type of FACTS devices family using power electronics to regulate voltage, control power flow and improve transient stability in power system. The SVC regulates voltage at its terminals by controlling the amount of reactive power injected into or absorbed from the power system. The SVC will generates reactive power (capacitive mode) when the system voltage is low and will absorbs reactive power (inductive mode) when the system voltage is high. The variation of the reactive power can be controlled by switching three-phase capacitor banks and inductor banks which are connected on the secondary side of a coupling transformer. Each capacitor bank is switched on and off by three Thyristor Switched Capacitor (TSC). Reactors are either switched on-off by Thyristor Switched Reactor (TSR) or phase-controlled Thyristor Controlled Reactor (TCR). [4]

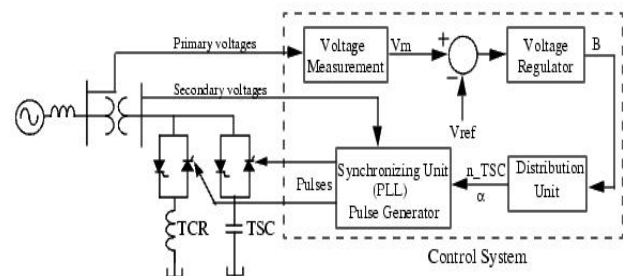

Fig.1.Schematic diagram of SVC [1]

Fig. shows Schematic Diagram of SVC. Svc is simulated in MATLAB by using phasor simulation, it consists of three phase power system together with generators, turbine models, motors and dynamics load to perform dynamic stability. It also consists of stepdown transformer, TCR (Thyristor switched capacitor), TSC (thyristor switched reactor), voltage regulators and phase locked loop (PLL). The control system consists of followings:

- [1]. A measurement system for measuring the positive-sequence voltage to be controlled.
- [2]. A voltage regulator that uses the voltage error (difference between the measured voltage V_m and

the reference voltage V_{ref}) to determine the SVC susceptance B needed to keep the system voltage constant.

- [3]. A distribution unit that determines the TSCs (and eventually TSRs) that must be switched in and out, and computes the firing angle α of TCRs
- [4]. A synchronizing system using a phase-locked loop (PLL) synchronized on the secondary voltages and a pulse generator that send appropriate pulses to the thyristors.[2]

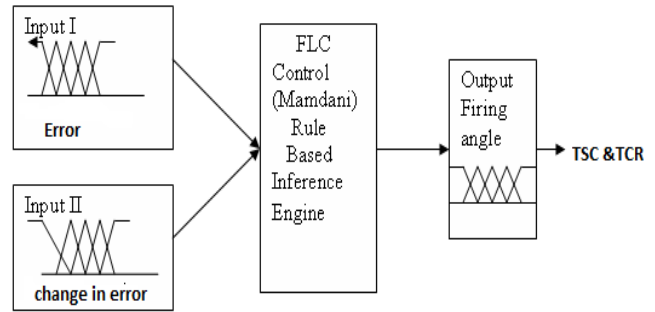

Fig. 2 The structure of fuzzy logic controller

III. FUZZY LOGIC CONTROLLER

Mamdani type membership rule is adopted for fuzzy logic interfacing. Load voltage and load current taken as input to fuzzy system. To get the linearity triangular membership function is taken with 50% overlap. The output of fuzzy controller is taken as the control signal. The Fuzzy Logic is a rule based controller, where a set of rules represents a control decision mechanism to correct the effect of certain causes coming from power system.[7] In fuzzy logic, the five linguistic variables expressed by fuzzy sets defined on their respective universes of discourse. The output of fuzzy controllers' works as a control signals for pulse generator and according to this firing angle is changed. [3]

Fuzzy logic is new control approach with great potential with real time applications .Due to simplest structure, easy designing and low cost, PI controller is used in SVC as voltage regulator in most industries. But its drawback is that due to highly nonlinearity, or uncertainty it is not able to control. Hence we need to design svc with fuzzy controller. There are two types of fuzzy controller which are Mamdani and Takagi-Sugeno. The difference between them is that the output membership function (MF) of Takagi-Sugeno is either linear or constant value [4].

Error in voltage and change in error is taken as two input of fuzzy logic controller. The output of fuzzy controller decides the control signal which supplied to firing angle control units .According to control signals the TSC and TCR is triggered. A fuzzy logic is rule base control mechanism which decides the control mechanism to correct the effect of certain causes coming from power system. In fuzzy logic seven linguist variable expressed by fuzzy sets. The structure of fuzzy logic controller is shown in figure 2

ΔE	E	NB	NM	NS	ZE	PS	PM	PB
NB		NB	NM	NS	NS	NS	NS	ZE
NM		NM	NM	NS	NS	NS	ZE	PS
NS		NM	NM	NS	NS	ZE	PS	PM
ZE		NB	NM	NS	ZE	PS	PM	PM
PS		NS	NS	ZE	PS	PS	PM	PM
PM		NS	ZE	PS	PS	PS	PM	PM
PB		ZE	PS	PS	PM	PM	PB	PB

fig. 3 Membership rules for controller

IV. TEST SYSTEM

A test system consists of 2 machines with 3 buses is considered. Plant 1 (M1) is a 1000 MW hydraulic generation plant is connected to a load centre through a long 500 kV, 700 km transmission line. The load centre is represented as a 5000 MW resistive load and supplied by the remote plant 2 (M2) consists of a 1000 MVA plant and a local generation of 5000 MVA.

A load flow has been performed on this system with M1 generating 950 MW and M2 generates 4046MW. The line carries 944 MW which is close to its surge impedance loading (SIL = 977 MW). A 200 MVAR SVC is implemented at the centre of the transmission line to maintain the system stability after faults occurrence. The two machines are equipped with a hydraulic turbine and governor (HTG), excitation system, and PSS. [2]

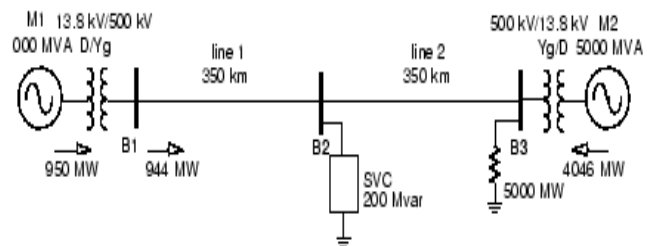

Fig:4 test system line diagramme

V. SIMULATION RESULTS

The performance of SVC with Fuzzy logic controller in power system oscillation damping after fault in two machine system is examined. Fig. shows simulink model of two machine power system. Three phase fault occurred at bus at Bus 1 for 0.1 second from $t_1=5s$ to $t_2=5.1s$. The effectiveness of the SVC with fuzzy logic controller is been observed. Fig. 6 shows the Fuzzy-SVC modelled in Simulink/MATLAB. After the fault occurred, the SVC will try to support the voltage by injecting reactive power on the line when the voltage is lower than the reference voltage (1.009 pu).

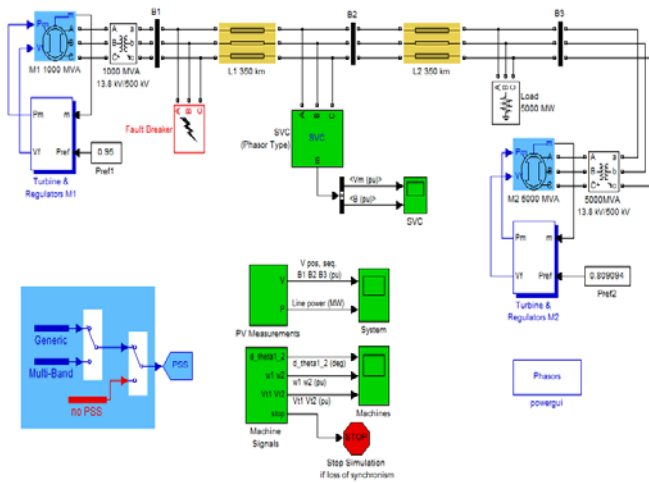

Fig: 5. Two-Machine 3-Bus Test System modeled in Simulink/MATLAB

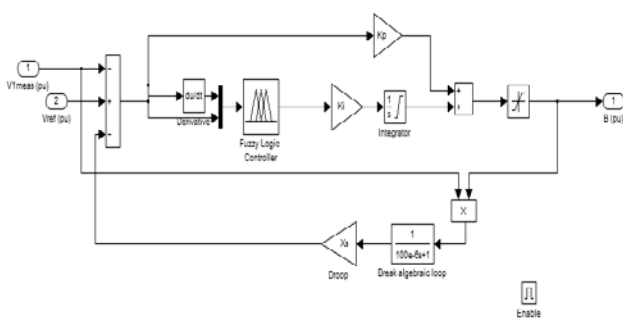

Fig: 6 Subsystem of test model

It is observed that as fault occurred between Bus 1 and Bus 2, terminal voltage V_{t1} is also affected. Observation from Fig. 7, V_{t1} is less oscillated and stabilized faster with the FUZZY-SVC controller used in the system.

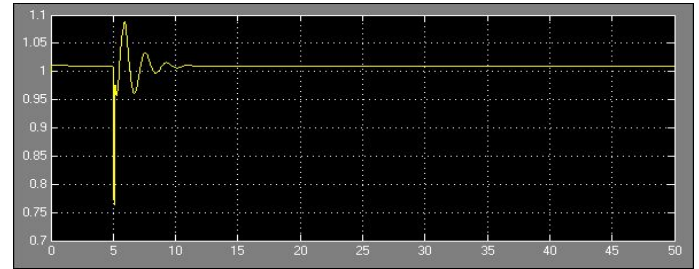

Fig: 7 Terminal voltage of system with svc during LG fault

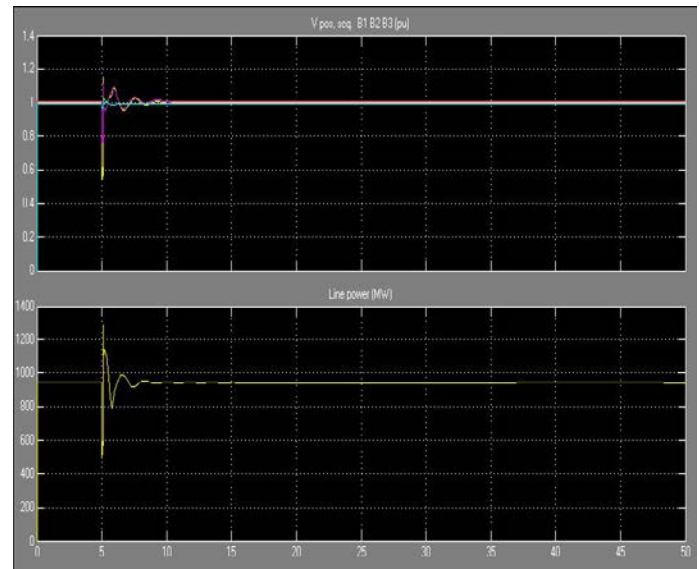

Fig:8 Positive sequence voltage and active power

Fig: 9 show the difference of rotor angle of Generator (G1) of the test system. After the occurrence of the three phase fault at $t_1=5s$, the two generators quickly fall out of synchronization. Observation from Fig.9 show that system implemented with FUZZY-SVC controller. The difference of rotor angle is stabilized faster with the controller at $t=10s$ which is 4.9 second after fault clearance.

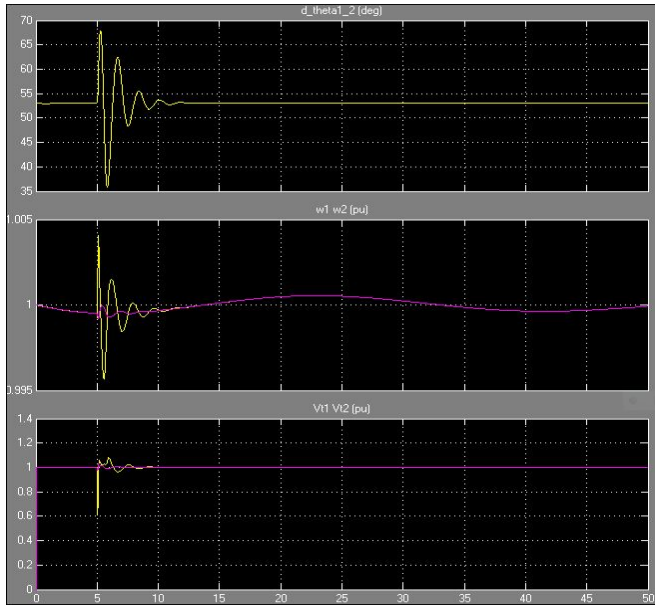

Fig: 9 Rotor angle oscillation of system with controller

VI. CONCLUSIONS

The SVC with fuzzy logic controller has been tested in a 2-machines 3-bus power system where several parameters including the difference of rotor angle between the machines, speed of the machines, terminal voltage and the transmission line active power have been observed. The performance of the system implemented with the FUZZY-SVC controller. The system implemented with the Fuzzy-SVC controller show better performance in damping oscillations, maintain terminal voltage and control the power after the system is subjected to disturbance.

References

- [1] N. G. Hingorani, L. Gyugyi, "Understanding FACTS; Concepts and Technology of Flexible AC Transmission Systems," IEEE Press book, 2000.
- [2] D.Jovicic, G.N.Pillai "Analytical Modeling of TCSC Dynamics" IEEE Transactions on Power Delivery, vol 20, Issue 2, April 2005, pp. 1097-1104
- [3] Puranik Sahu, Arun Pachori "voltage stability improvement using static var compensator with fuzzy controller in power systems" VSRD International Journal of Electrical, Electronics & Communication Engineering, Vol. 3 No. 5 May 2013
- [4] N. A. Arzaha, M. W. Mustafa and R. Mohamad Idris, "Fuzzy-based Static VAR Compensator Controller for Damping Power System Disturbances," IEEE conference on power engineering and optimization, Malaysia, June 2012.
- [5] A. Kazemi and M.V. Sohrforouzani, "Power system damping using fuzzy controlled facts devices," Electrical Power and Energy Systems, vol. 28, pp.349-357, 2006.
- [6] N.Karpagam, D.Devaraj, "Fuzzy logic control of static VAR compensator for power system damping," World Academy of Science, Engineering and Technology, pp. 663- 669, 2000.
- [7] Timothy J Ross, —Fuzzy Logic with Engineering Applications, McGraw-Hill, Inc, New York, 1997.

- [8] A.E. Hammad, "Comparing the voltage control Capabilities of present and future VAR compensating techniques in transmission systems," IEEE Trans. Power Delivery, vol.11, no.1, pp. 475484, Jan.1996
- [9] K. L. Lo and Khan Laiq, "Fuzzy logic based SVC for power system transient stability enhancement, International Conference on Electric Utility Deregulation and Restructuring and Power Technologies (DRPT 2000), April 2000, pp.453- 458.
- [10] Vladimiro Miranda, "An improved Fuzzy Voltage Inference System for VAR control" IEEE Transactions, on Power Systems, vol.22 No.4, November 2000