

CONTROL OF POWER SYSTEM STABILITY THROUGH FACTS

Rajesh Kumar Dubey & Sumit Kumar Suman

Department of Electronics & Communication Engineering, Swami Vivekanand University, Sagar(MP)

ABSTRACT

The objective of this paper to investigate and understand the stability of power system, with the main focus on stability and power system modeling. The power generation and transmission is a complex process, requiring the working of many components of the power system in tandem to maximize the output. Electric power grid is a widely distributed system, consisting of dispersed generators interconnected through transmission lines, mounting real and reactive power compensators, etc. Moreover, with deregulation and growth of the power industry, power systems elements are forced to operate very near to their maximum capacity and hence, the system became vulnerable. Therefore, controlled operation of power systems is very critical and of utmost importance in order to achieve stable power system. The basic purpose of FACTS is installing the power electronics devices at the high voltage side of the power grid to make the complete system electronically controllable. Because of high power semiconductor devices and control technology FACTS devices plays a vital role in power systems.

Keywords - Power Supply, AC, FACTS, Transmission lines, Power, Power grid

1. INTRODUCTION

Stable operation of highly interconnected, geographically wide power system craves for matching of total generation with total load demand along with associated system losses [1]. On one hand, interconnection, restructuring of power system has brought very economical and quality energy for consumers. Poles apart, deregulation and with the increase of fast power consumption loads, such as testing plants, nuclear fusion plants, factories using arc furnace transformer have made the matching very critical. Additionally, power systems have become more unpredictable after the implementation of high speed electronic power controllers. Flexible AC Transmission System. (FACTS) is a static equipment used for the AC transmission of electrical energy. It is meant to enhance controllability and increase power transfer capability. It is generally a power electronics based. The application of multiple flexible AC system (FACTS) controllers has received considerable recent interest as a means of enhancing system dynamic performance [2 – 4]. Most available techniques for their design focus on the use of simple eigen value-based study techniques derived from sensitivity analyses of the state representation. While these approaches are very simple, leading to standard eigen value problems, FACTS controllers may interact with other controllers leading to performance deterioration [6]. The review of reference [7] has revealed that, yet full advantages offered by restructuring electric power utility are not availed because of inappropriate control algorithms. The importance of enhanced operation and control of power system has increased particularly after recent interconnected blackouts in USA, UK and Europe, also [8].

Nowadays, power systems are observing shift from vertical integration to horizontal operation where competitive companies own GENCOs, TRANSCO and DISCOs. This transition has resulted in power systems being operated at ever lesser security and stability margin and hence, threatening power systems reliability. Additionally, recent control actions are not designed for fast propagating disturbances [9]. Reference [10] provides excellent understanding about the impact of de-regularization of utility on planning and management of the utility. As power systems continue to grow in size and complexity, it becomes increasingly important to comprehend system stability to preclude dynamic collapse and possible blackouts.

Research in power systems is currently being carried out in areas of power system transient stability [11], power quality [12], data quality [13], power system modeling [14], power system reliability [15], fast valving [16], reactive power management [17], power systems economics [18] and integration of renewable sources with national grid as the title suggests this research work is concerned with power system stability.

2. CONTROL OF POWER SYSTEMS

2.1. Generation, Transmission, Distribution of Electrical Power

In any power system, the creation, transmission, and utilization of electrical power can be separated into three areas, which traditionally determined the way in which electric utility companies had been organized. Although power electronic based equipment is prevalent in each of these three

areas, such as with static excitation systems for generators and Custom Power equipment in distribution systems [8], the focus of this paper and accompanying presentation is on transmission, i.e, moving the power from where it is generated to where it is utilized.

Generation -----Transmission ----- Distribution

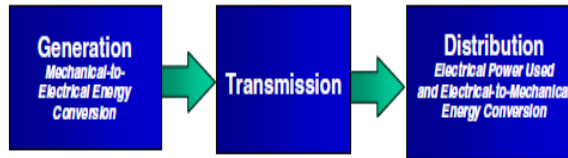

Fig – 1 Block diagram of generation, transmission & distribution

2.2. PS Control System

As we know that the transmission systems are being pushed closer to their stability and thermal limits while the focus on the quality of power delivered is greater than ever. The limitations of the transmission system can take many forms and may involve power transfer between areas or within a single area or region and may include one or more of the following characteristics:

Short-Circuit Current Limit, Steady-State Power Transfer Limit, Voltage Stability Limit, Dynamic Voltage Limit, Transient Stability Limit, Power System Oscillation Damping Limit, Inadvertent Loop Flow Limit, Thermal Limit and others.

Each transmission bottleneck or regional constraint may have one or more of these system-level problems. The key to solving these problems in the most cost-effective and coordinated manner is by thorough systems engineering analysis.

2.3. Controllability of Power Systems

To illustrate that the power system only has certain variables that can be impacted by control, we have considered here the power-angle curve, shown in Figure 2. Although this is a steady-state curve and the implementation of FACTS is primarily for dynamic issues, this illustration demonstrates the point that there are primarily three main variables that can be

directly controlled in the power system to impact its performance. These are Voltage, Angle & Impedance.

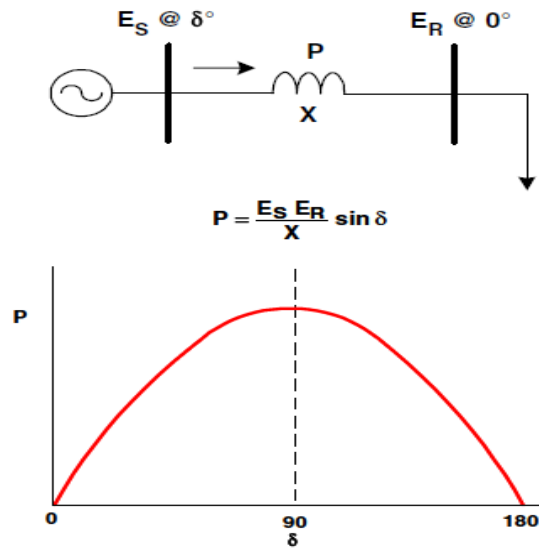

Fig – 2. Illustration of controllability of power systems

We can also infer the point that direct control of power is a fourth variable of controllability in

power systems. With the establishment of “what” variables can be controlled in a power system, the next question is “how” these variables can be controlled. The answer is presented in two parts: namely conventional equipment and FACTS controllers.

Examples of Conventional Equipment For Enhancing PS Control

There are following examples for PS Control

Transformer LTC -Controls voltage, Switched Shunt-Capacitor and Reactor -Controls voltage, Series Capacitor -Controls impedance, Phase Shifting Transformer -Controls angle
Synchronous Condenser -Controls voltage, Special Stability Controls-Focuses on voltage control but often include direct control of power, Others (When Thermal Limits are Involved) - Can Included reconductoring, raising conductors, dynamic line monitoring, adding new lines, etc.

Example of FACTS Controllers for Enhancing P S Control

Static Synchronous Compensator (STATCOM)-Controls voltage, Static VAR Compensator (SVC)-Controls voltage, Unified Power Flow Controller (UPFC), Convertible Series Compensator (CSC), Inter-phase Power Flow Controller (IPFC), Static Synchronous Series Controller (SSSC).

Each of the above mentioned controllers have impact on voltage, impedance, and/or angle (and power)

- Thyristor Controlled Series Compensator (TCSC)-Controls impedance
- Thyristor Controlled Phase Shifting Transformer (TCPST)-Controls angle
- Super Conducting Magnetic Energy Storage (SMES)-Controls voltage and power

2.4. Benefits of Control of Power Systems

Once power system constraints are identified and through system studies viable solutions options are identified, the benefits of the added power system control must be determined. The following offers a list of such benefits:

- Increased Loading and More Effective Use of Transmission Corridors
- Added Power Flow Control
- Improved Power System Stability
- Increased System Security
- Increased System Reliability
- Added Flexibility in Starting New Generation
- Elimination or Deferral of the Need for New Transmission Lines

2.5. Benefits of utilizing FACTS devices

The benefits of utilizing FACTS devices in electrical transmission systems can be summarized as follows [1]:

- Better utilization of existing transmission system assets
- Increased transmission system reliability and availability
- Increased dynamic and transient grid stability and reduction of loop flows
- Increased quality of supply for sensitive industries
- Environmental benefits Better utilization of existing transmission system assets

2.6. Classification

There are different classifications for the FACTS devices: Depending on the type of connection to the network FACTS devices can differentiate four categories

Serial Controllers, Derivation Controllers, Serial to Serial Controllers, Serial-Derivation Controllers

Depending on technological features, the FACTS devices can be divided into two generations

first generation: used thyristors with ignition controlled by gate (SCR).

There are different classifications for the FACTS devices: Depending on the type of connection to the network FACTS devices can differentiate four categories as Serial Controllers, Derivation Controllers, Serial to Serial Controllers and Serial-derivation controllers.

Depending on technological features, the FACTS devices can be divided into two generations

First generation: used thyristors with ignition controlled by gate (SCR).

Second generation: semiconductors with ignition and extinction controlled by gate (GTO, MCT, IGBT, IGCT, etc).

These two classifications are independent, existing for example, devices of a group of the first classification that can belong to various groups of the second classification. The main difference between first and second generation devices is the capacity to generate reactive power and to interchange active power. The first generation FACTS devices work like passive elements using impedance or tap changer transformers controlled by thyristors. The second generation FACTS devices work like angle and module controlled voltage sources and without inertia, based in converters, employing electronic tension sources (three-phase inverters, auto-switched voltage sources, synchronous voltage sources, voltage source control) fast proportioned and controllable and static synchronous voltage and current sources.

3. FIRST GENERATION OF FACTS

3.1. Static VAR Compensator (SVC)

A static VAR compensator (or SVC) is an electrical device for providing fast-acting reactive power on high-voltage electricity transmission networks. SVCs are part of the Flexible AC transmission system device family, regulating voltage and stabilizing the system. The term "static" refers to the fact that the SVC has no moving parts (other than circuit breakers and disconnects, which do not move under normal SVC operation). Prior to the invention of the SVC, power factor compensation was the preserve of large rotating machines such as synchronous condensers. The SVC is an automated impedance matching device, designed to bring the system closer to unity power factor. If the power system's reactive load is capacitive (leading), the SVC will use reactors (usually in the form of Thyristor-Controlled Reactors) to consume VARs from the system, lowering the system voltage. Under inductive (lagging) conditions, the capacitor banks are automatically switched in, thus providing a higher system voltage. They also may be placed near high and rapidly varying loads, such as arc furnaces, where they can smooth flicker voltage. It is known that the SVCs with an auxiliary injection of a suitable signal can considerably improve the dynamic stability performance of a power system. It is observed that SVC controls can significantly influence nonlinear system behavior especially under high-stress operating conditions and increased SVC gains.

3.2. Thyristor-Controlled Series Capacitor (TCSC) TCSC controllers use thyristor-controlled reactor (TCR) in parallel with capacitor segments of series capacitor bank. The combination of TCR and capacitor allow the capacitive reactance to be smoothly controlled over a wide range and switched upon command to a condition where the bi-directional thyristor pairs conduct continuously and insert an inductive reactance into the line. TCSC is an effective and economical means of solving problems of transient stability, dynamic stability, steady state stability and voltage stability in long transmission lines. TCSC, the first generation of FACTS, can control the line impedance through the introduction of a thyristor controlled capacitor in series with the transmission line. A TCSC is a series controlled capacitive reactance that can provide continuous control of power on the ac line over a wide range. The functioning of TCSC can be comprehended by analyzing the behavior of a variable inductor connected in series with a fixed capacitor

3.3. Thyristor-Controlled Phase Shifter (TCPS)

In a TCPS control technique the phase shift angle is determined as a nonlinear function of rotor angle and speed. However, in real-life power system with a large number of generators, the rotor angle of a single generator measured with respect to the system reference will not be very meaningful.

4. SECOND GENERATION OF FACTS

4.1. Static Compensator (STATCOM)

The emergence of FACTS devices and in particular GTO thyristor-based STATCOM has enabled such technology to be proposed as serious competitive alternatives to conventional SVC [21] A static synchronous compensator (STATCOM) is a regulating device used on alternating current electricity transmission networks. It is based on a

power electronics voltage-source converter and can act as either a source or sink of reactive AC power to an

electricity network. If connected to a source of power it can also provide active AC power. It is a member of the FACTS family of devices. Usually a STATCOM is installed to support electricity networks that have a poor power factor and often poor voltage regulation. There are however, other uses, the most common use is for voltage stability. From the power system dynamic stability viewpoint, the STATCOM provides better damping characteristics than the SVC as it is able to transiently exchange active power with the system.

4.2. Static Synchronous Series Compensator (SSSC)

This device work the same way as the STATCOM. It has a voltage source converter serially connected to a transmission line through a transformer. It is necessary an energy source to provide a continuous voltage through a condenser and to compensate the losses of the VSC. A SSSC is able to exchange active and reactive power with the transmission system. But if our only aim is to balance the reactive power, the energy source could be quite small. The injected voltage can be controlled in phase and magnitude if we have an energy source that is big enough for the purpose. With reactive power compensation only the voltage is controllable, because the voltage vector forms 90° degrees with the line intensity. In this case the serial injected voltage can delay or advanced the line current. This means that the SSSC can be uniformly controlled in any value, in the VSC working slot.

4.3. Unified Power Flow Controller (UPFC)

A unified power flow controller (UPFC) is the most promising device in the FACTS concept. It has the ability to adjust the three control parameters, *i.e.* the bus voltage, transmission line reactance, and phase angle between two buses, either simultaneously or independently. A UPFC performs this through the control of the in-phase voltage, quadrature voltage, and shunt compensation. The UPFC is the most versatile and complex power electronic equipment that has emerged for the control and optimization of power flow in electrical power transmission systems. It offers major potential advantages for the static and dynamic operation of transmission lines. The UPFC was devised for the real-time control and dynamic compensation of ac transmission systems, providing multifunctional flexibility required to solve many of the problems facing the power industry. Within the framework of traditional power transmission concepts, the UPFC is able to control, simultaneously or selectively, all the parameters affecting power flow in the transmission line. Alternatively, it can independently control both the real and reactive power flow in the line unlike all other controllers.

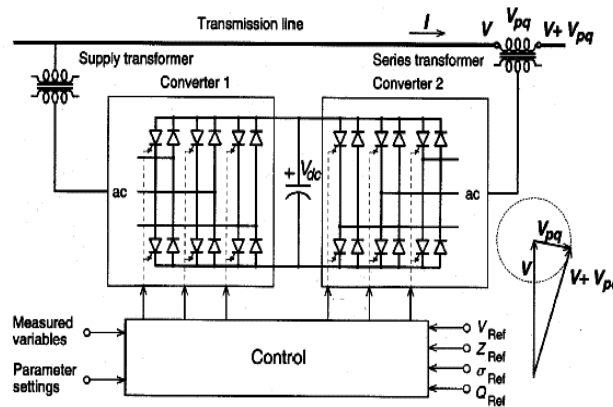

Fig – 3. Unified Power Flow Controller

5. TYPES OF NETWORK CONNECTION

5.1. Serial controllers.

It can consist of a variable impedance as a condenser, coil, etc or a variable electronics based source at a fundamental frequency. The principle of operation of all serial controllers is to inject a serial tension to the line. A variable impedance multiplied by the current that flows through it represents the serial tension.

While the tension is in quadrature with the line current the serial controller only consumes reactive power; any other phase angle represents management of active power. A typical controller is Serial Synchronous Static Compensator (SSSC).

5.2. Controllers in derivation.

As it happens with the serial controller, the controller in derivation can consist of a variable impedance, variable source or a combination of both. The operation principle of all controllers in derivation is to inject current to the system in the point of connection. A variable impedance connected to the line tension causes variable current flow, representing an injection of current to the line. While the injected current is in quadrature with the line tension, the controller in derivation only consumes reactive power; any other phase angle represents management of active power. A typical controller is Synchronous Static Compensator (STATCOM).

5.3. Serial-serial Controllers.

This type of controllers can be a combination of coordinated serial controllers in a multiline transmission system. Or can also be an unified controller in which the serial controllers provide serial reactive compensation for each line also transferring active power between lines through the link of power. The active power transmission

capacity, that present a unified serial controller or line feed power controller, makes possible the active and reactive power flow balance and makes the use of transmission bigger. In this case, the term “unified” means that the DC terminals of the converters of all the controllers are connected to achieve a transfer of active power between each other. A typical controller is the Interline Power Flow Compensator (IPFC).

5.4. Serial-derivation Controllers.

This device can be a combination of serial and derivations controllers separated, coordinately controlled or a unified power flow controller with serial and derivation elements. The principle of operation of the serial-derivation controllers is to inject current to the system through the component in derivation of the controller, and serial tension with the line utilizing the serial component. When the serial and derivation controllers are unified, they can have an exchange of active power between them through their link. A typical controller is Unified Power Flow Controller (UPFC), which incorporating function of a filtering and conditioning becomes a Universal Power Line Conditioner (UPLC).

6. FACTS APPLICATIONS TO STEADY STATE POWER SYSTEM PROBLEMS

For the sake of completeness of this review, a brief overview of the FACTS devices applications to different steady state power system problems is presented in this section. Specifically, applications of FACTS in optimal power flow and deregulated electricity market will be reviewed.

6.1. FACTS Applications to Optimal Power Flow

In the last two decades, researchers developed new algorithms for solving the optimal power flow problem incorporating various FACTS devices [11]. Generally in power flow studies, the thyristor controlled FACTS devices, such as SVC and TCSC, are usually modeled as controllable impedance [4, 9, 10, 12-14]. However, VSC-based FACTS devices, including IPFC and SSSC, shunt devices like STATCOM, and combined devices like UPFC, are more complex and usually modeled as controllable sources [4, 9, 13-17, 20]. The Interline Power Flow Controller (IPFC) is one of the voltage source converter (VSC) based FACTS Controllers which can effectively manage the power flow via multi-line Transmission System.

6.2. FACTS Applications to Deregulated Electricity Market

Nowadays, electricity demand is rapidly increasing without major reinforcement projects to enhance

power transmission networks. Also, the electricity market is going toward open market and deregulation creating an environment for forces of competition and bargaining. FACTS devices can be an alternative to reduce the flows in heavily loaded lines, resulting in an increased load ability, low system loss, improved stability of the network, reduced cost of production, and fulfilled contractual requirements by controlling the power flows in the network. Generally, the changing nature of the electricity supply industry is introducing many new subjects into power system operation related to trading in a deregulated competitive market. Commercial pressures on obtaining greater returns from existing assets suggests an increasingly important role for dynamic network management using FACTS devices and energy storage as an important resource in generation, transmission, distribution, and customer service. There

has been an increased use of the FACTS devices applications in an electricity market having pool and contractual dispatches.

7. APPLICATIONS AND TECHNICAL BENEFITS OF FACTS

The technical benefits of the principal for dynamic applications of FACTS in addressing problems in transient stability, dampening, post contingency voltage control and voltage stability are summarized in Table-1. FACTS devices are required when there is a need to respond to dynamic (fast-changing) network conditions. The conventional solutions are normally less expensive than FACTS devices, but limited in their dynamic behavior. It is the task of the planners to identify the most economic solution.

	Load Flow Control	Voltage Control	Transient Stability	Dynamic Stability
SVC	●	●●●●	●	●●
STATCOM	●	●●●●	●●	●●
TCSC	●●	●	●●●●	●●
UPFC	●●●●	●●●●	●●	●●

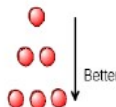

Table 1. Technical benefits of the main FACTS devices

8. CONCLUSION

The essential features of FACTS controllers and their potential to improve system stability is the prime concern for effective & economic operation of the power system. The location and feedback signals used for design of FACTS-based damping controllers were discussed. The coordination problem among different control schemes was also considered. Performance comparison of different FACTS controllers has been reviewed. The likely future direction of FACTS technology, was discussed. In addition, utility experience and major real-world installations and semiconductor technology development have been summarized. A brief review of FACTS applications to optimal power flow and deregulated electricity market has been presented.

REFERENCES

[1] Z Y, Lui Electric Power System Dynamics. Academic Press, 1983.

[2] M. A. Abdel-Moamen and N. P. Padhy, “Optimal Power Flow Incorporating FACTS Devices Bibliography and Survey”, IEEE PES Transmission and Distribution Conference and Exposition, 7–12 September 2003, vol. 2, pp. 669 – 676

[3] J. R. Smith, G. Andersson, and C. W. Taylor, “Annotated Bibliography on Power System Stability Controls: 1986- 1994”, IEEE Trans. on PWRs, 11(2)(1996), pp.794–800.

[4] N. G. Hingorani and L. Gyugyi, Understanding FACTS: Concepts and Technology of Flexible AC Transmission Systems. New York: IEEE Press, 2000.

[5] N. G. Hingorani, “FACTS-Flexible AC Transmission System”, Proceedings of 5th International Conference on AC and DC Power Transmission-IEE Conference Publication

345, 1991, pp. 1–7.

- [6] N. G. Hingorani, "Flexible AC Transmission", IEEE Spectrum, April 1993, pp. 40–45.
- [7] N. G. Hingorani, "High Power Electronics and Flexible AC Transmission System", IEEE Power Engineering Review, July 1988.
- [8] R. M. Mathur and R. S. Basati, Thyristor- Based FACTS Controllers for Electrical Transmission Systems. IEEE Press Series in Power Engineering, 2002.
- [9] Yong Hua Song and Allan T. Johns, Flexible AC Transmission Systems (FACTS). London, UK: IEE Press, 1999.
- [10] M. Noroozian and G. Andersson, "Power Flow Control by Use of Controllable Series Components", IEEE Trans. PWRD, 8(3)(1993), pp. 1420–1429.
- [11] P. W. Sauer and M. A. Pai, Power System Dynamics and Stability. Prentice Hall, 1998.
- [12] E. Acha, C.R. Fuerte-Esquivel, and H. Ambriz-Perez, "Advanced SVC model for Newton-Raphson Load Flow and Newton Optimal Power Flow Studies", IEEE Trans. PWRD, 15(1)(2000), pp. 129–136.
- [13] E. Acha, C. R. Fuerte-Esquivel, and H. Ambriz-Perez et al., FACTS: Modeling and Simulation in Power Networks, London, U.K.: Wiley, 2004.
- [14] D. J. Gotham and G. T. Heydt, "Power Flow Control and Power Flow Studies for Systems with FACTS Devices", IEEE Trans. PWRD, 13(1)(1998), pp. 60–65.
- [15] L. Gyugyi, K. K. Sen, and C. D. Schauder, "The Interline Power Flow Controller Concept: a New Approach to Power Flow Management in Transmission Systems", IEEE Trans. PWRD, 14(3)(1999), pp. 1115–1123.
- [16] T. S. Chung, D. Qifeng, Z. Bomina, "Optimal Active OPF with FACTS Devices by Innovative Load-Equivalent Approach", IEEE Power Engineering Review, 20(5)(2000), pp. 63–66.
- [17] Ying Xiao, Y. H. Song, and Y. Z. Sun, "Power Flow Control Approach to Power Systems With Embedded FACTS Devices", IEEE Trans. on PWRD, 17(4)(2002), pp. 943–950
- [18] X. Dai, J. Liu, Y. Tang, N. Li, and H. Chen, "Neural Network α -Order Inverse Control of Thyristor Controlled Series Compensator", Electric Power Systems Research, 45(1998), pp. 19–27.
- [19] T. Senjyu, S. Yamane, Y. Morishima, K. Uezato, and H. Fujita, "Improvement of Multimachine Power System Stability with Variable Series Capacitor Using On-Line Learning Neural Network", Int. J. Electrical
- [20] P.K.Rai and Sumit K. Lal "Power analysis based on algorithm" Journal of Ultra Sciences, 9(6)(2014) PP 1024-29.
- [21] Larsen EV, Sanchez-Gasca JJ, Chow JH. Concepts for design of FACTS controllers to damp power swings. IEEE/PES Summer Meeting, San Francisco, CA; July 1994.
- [22] Rouco L. Coordinated design of multiple controllers for damping power system oscillations. Electr Power Energy Syst 2001;23 517 – 30.





