

## **INVESTIGATIONS ON THE FLUID COUPLING OF GEARLESS TWO WHEELER**

<sup>1</sup>**SYED DANISH MEHDI, ASST. PROF., VIF COLLEGE OF ENGG. AND TECH.**

<sup>2</sup>**DR. MOHD. MOINODDIN, ASSOC. PROF., MJCET**

<sup>3</sup>**DR. SYED NAWAZISH MEHDI, PROFESSOR, MJCET**

### **ABSTRACT**

There is an increased attention towards the development of Gear-less two-wheeler automobiles [scooters] which have automatic-transmission systems, using centrifugal-clutch systems. These clutch systems have high wear and tear and hence the present research work is taken up to replace the said clutch system with a fluid coupling which may be more effective in wear-free transmission and it will provide a smooth & controlled acceleration with effective damping of shocks, load fluctuations and torsional vibrations. The attention is therefore laid on developing a highly-efficient fluid coupling. This fluid coupling would capture the mechanical power from the main source, namely the I.C. engine and then transmits it to the rear wheels via an automatic gear box. The fluid coupling has an advantage over the mechanical coupling in the following areas. Effective dampening of shocks, load fluctuations and torsional vibrations. Smooth and controlled acceleration without jerks in transmission of the vehicle. Wear-free power transmission because of absence of mechanical connection [no metal-to-metal contact] between the input and output elements. But as the Conventional-fluid couplings have relatively low transmission efficiency, the challenge lies in developing an efficient modified fluid coupling which would transfer the mechanical power with minimum transmission losses in the case of Two-Wheeler automobiles especially the Gear-less Scooters. Presently these vehicles are using a Centrifugal-clutch which has maximum wear and tear frequently. Using the solid works software a fluid coupling was modelled by adjusting the gap between the driver and driven shaft and an estimate of the efficiency was also known. Based on the recommendations of a computational study an initial estimate of the efficiency of a basic modified-fluid coupling design without vanes and consequently in making recommendations on

scope for further design improvements i.e. using vanes on the two discs].Based on the recommendations from the computational study a conventional fluid coupling with one driver shaft and one driven shaft will be fabricated and tested.

## **INTRODUCTION**

Old mobiles 1940 models featured hydra matic drive the first mass production fully automatic transmissions. Initially an old exclusive hydra matic had a fluid coupling (not a torque converter) and three planetary gear sets providing four speeds plus reverse. Hydramatic was subsequently adopted by Cadillac and Pontiac, and was sold to various other automakers, including Bentley, Hudson, Kaiser, Nash and Rolls-royce.From 1950 to 1954 Lincoln cars were also available with GM hydra matic. Mercedes benz subsequently devised a four speed fluid coupling transmission that was similar in principle to hydra matic but did not share the same design. The first torque converter automatic buicks dyna flow, was introduced for the 1948model year. It was followed by Chevrolets power glide and packards ultramatic for the1950 model year. Each of these transmissions had only two forward speeds relying on the torque converter for additional gear reduction. In the early 1950s Borg-warner developed a series of three speed torque converter automatics for ford motor company. Studebaker and several foreign independent makes Chrysler was late in developing its own true automatic, introducing the two-speed torque converter power in 1953 and the three speed power flite in 1956. By the late 1960s most of the fluid coupling four speed and two speed transmissions had disappeared in favor of three speed units with torque converters. By the early 1980s these were being supplemented and eventually replaced by over drive equipped transmissions providing four or more forward speeds. Many transmissions also adopted the lock-up torque converter to improve fuel economy. As the engine computers became more and more capable and even more of the valves body functionality was offloaded to them. These transmissions introduced in the late 1980s and early 1990s remove almost all of the control logic from the valve body and place it in into the engine computer. In this case solenoids turned on and off by the computer control shift

patterns and gear ratios rather than the spring loaded valves in the valve body. ZF Friedrichshafen AG and BMW were responsible for introducing the first five speed automatic and the first six speed (ZF 6HP26 in the 2002 BMW E65 7 series). Mercedes Benz was the first seven speeds in 2003 with Toyota motor company introducing an 8 speed in 2007 on the Lexus LS.

In modern usage, a torque converter is generally a type of hydrodynamic fluid coupling that is used to transfer rotating power from a prime mover, such as an internal combustion engine or electric motor, to a rotating driven load. The torque converter normally takes the place of a mechanical clutch in a vehicle with an automatic transmission, allowing the load to be separated from the power source. It is usually located between the engine's flex plate and the transmission. The key characteristic of a torque converter is its ability to multiply torque when there is a substantial difference between input and output rotational speed, thus providing the equivalent of a reduction gear. Some of these devices are also equipped with a temporary locking mechanism which rigidly binds the engine to the transmission when their speeds are nearly equal, to avoid slippage and a resulting loss of efficiency.



Figure 1:Torque Converter

A fluid coupling is a two element drive that is incapable of multiplying torque, while a torque converter has at least one extra element—the stator—which alters the drive's characteristics during periods of high slippage, producing an increase in output torque. In a torque converter

there are at least three rotating elements: the impeller, which is mechanically driven by the prime mover the turbine, which drives the load and the stator, which is interposed between the impeller and turbine so that it can alter oil flow returning from the turbine to the impeller. The classic torque converter design dictates that the stator be prevented from rotating under any condition, hence the term *stator*. In practice, however, the stator is mounted on an overrunning clutch, which prevents the stator from counter-rotating with respect to the prime mover but allows forward rotation. Modifications to the basic three element design have been periodically incorporated, especially in applications where higher than normal torque multiplication is required. Most commonly, these have taken the form of multiple turbines and stators, each set being designed to produce differing amounts of torque multiplication. For example, the Buick Dyna flow automatic transmission was a non-shifting design and, under normal conditions, relied solely upon the converter to multiply torque. The Dyna flow used a five element converter to produce the wide range of torque multiplication needed to propel a heavy vehicle. Although not strictly a part of classic torque converter design, many automotive converters include a lock-up clutch to improve cruising power transmission efficiency and reduce heat. The application of the clutch locks the turbine to the impeller, causing all power transmission to be mechanical, thus eliminating losses associated with fluid drive.

An automatic transmission uses a fluid coupling torque converter to replace the clutch to avoid engaging/disengaging clutch during gear change. A completed gear set, called planetary gears, is used to perform gear ratio change instead of selecting gear manually. With the invention of the automatic transmission, a driver no longer needs to worry about gear selection during driving. It makes driving a car much easier, especially for a disabled or new driver. However the indirect gear contact of the torque converter causes power loss during power transmission, and the complicated planetary gear structure makes the transmission heavy and easily broken.

Unlike a manual transmission system, automatic transmission does not use a clutch to disconnect power from the engine temporarily when shifting gears. Instead, a device called a torque converter was invented to prevent power from being temporarily disconnected from the engine and also to prevent the vehicle from stalling when the transmission is in gear. Consider two fans facing each

other: when one of them is turned on and starts spinning, the other one will also start spinning at lower speed (see figure ). That's because the first fan moves the air to drive the second fan to spin. This is the same idea as the torque converter of an automatic transmission system, except that it uses fluid instead of air as the transportation media.

Automatic transmission fluid (ATF) is the fluid used in vehicles with self shifting. It is typically coloured red or green to differentiate it from motor oil in the vehicle. The fluid is highly specialised oil optimized for the special requirements of a transmission. Modern fluids typically contain a wide variety of chemical compounds intended to provide required properties of a particular fluid specification. Most fluids contain some combination of additives that improve lubricating qualities such as wear resistant, corrosion resistant inhibitors, detergents, dispersants and surfactants (which protect and clean metal surfaces

Fluid coupling fluid is blended with the finest solvent refined hydro-finished which is with high viscosity index upto 100% paraffin base stocks available. These solvent refined hydro finished paraffin base stocks provide simplex fluid coupling fluid with superior oxidation resistance and also excellent thermal stability.

## MODELLING OF MODIFIED FLUID COUPLING

### *3.2 Modified Fluid Coupling And Experimental Set Up Modelling*

Solid modelling of modified fluid coupling and the entire experimental setup is done using solid works 2008 software. Following are the sub sequent images for the model of the experimental set up.

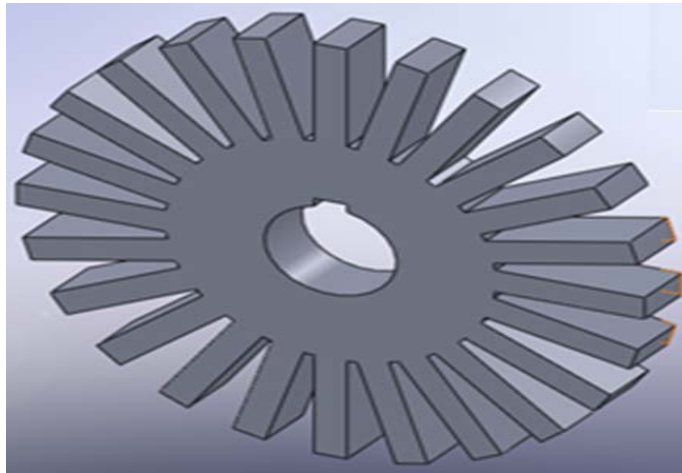

Figure 3.1: impeller straight

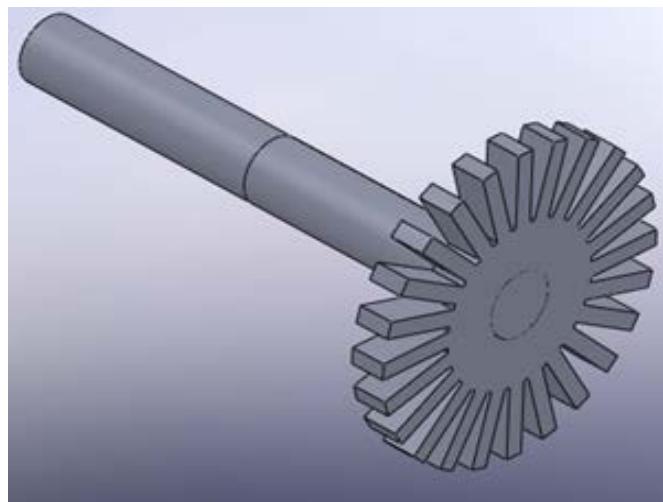

Figure3.2 straight impeller with shaft

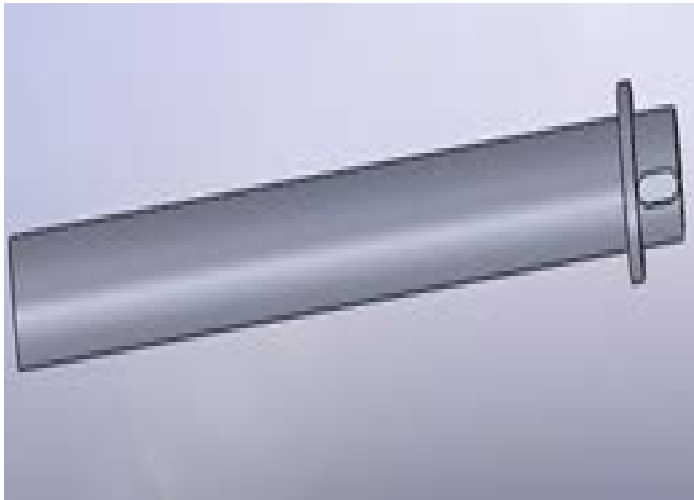
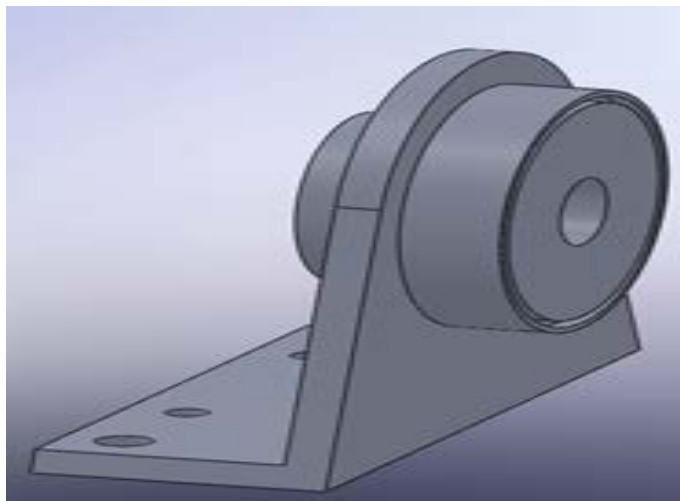

Figure 3.3: shaft



3.4:outer casing

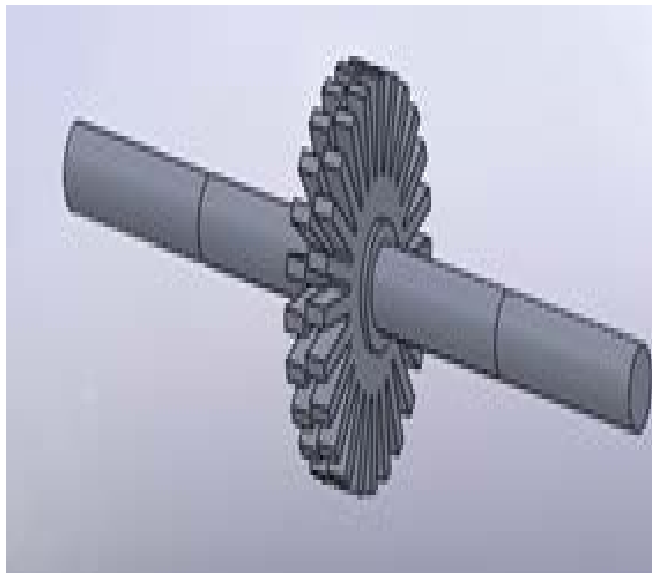
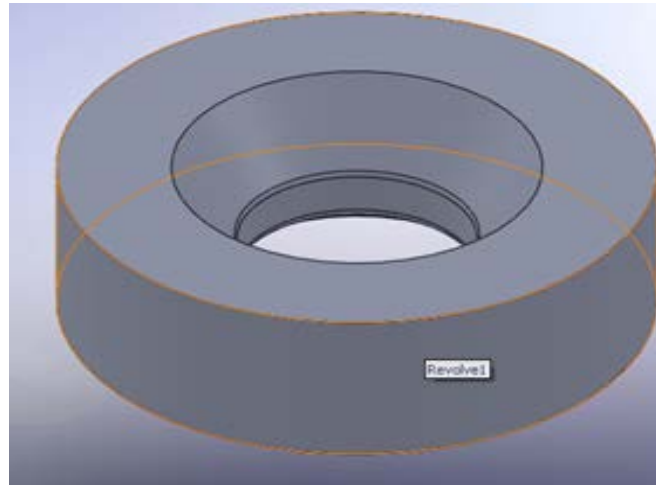

Figure 3.5,3.6: oil seal ,final assembly straight



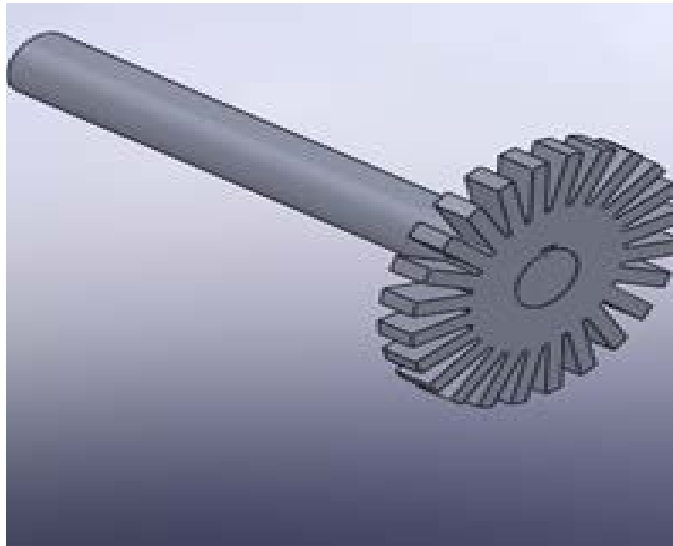
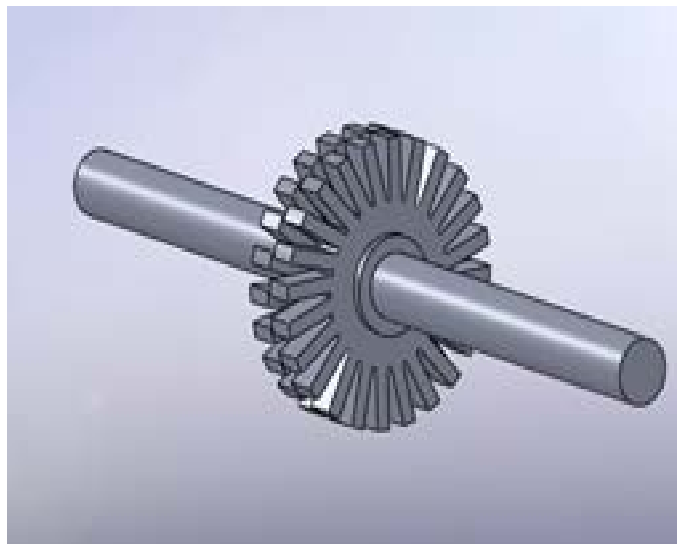

Figure 3.7: 15 degree assembly impeller



3.8: final assembly 15 degree

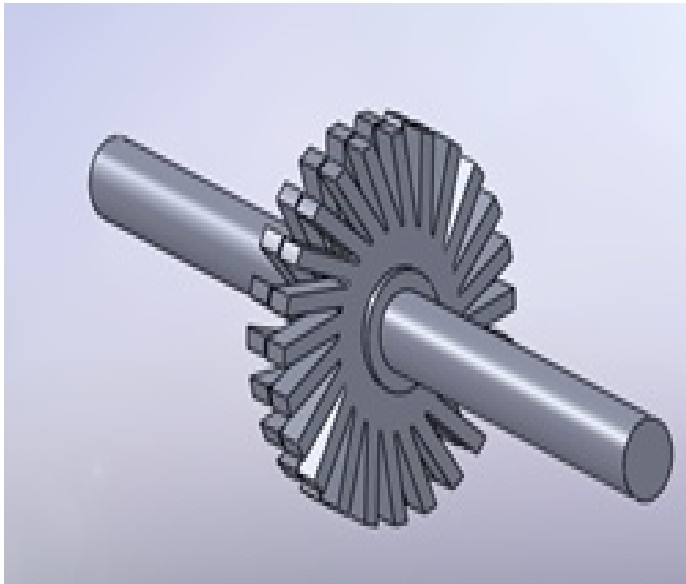

Figure 3.9: final assembly 30degrees



Figure 3.10:oring

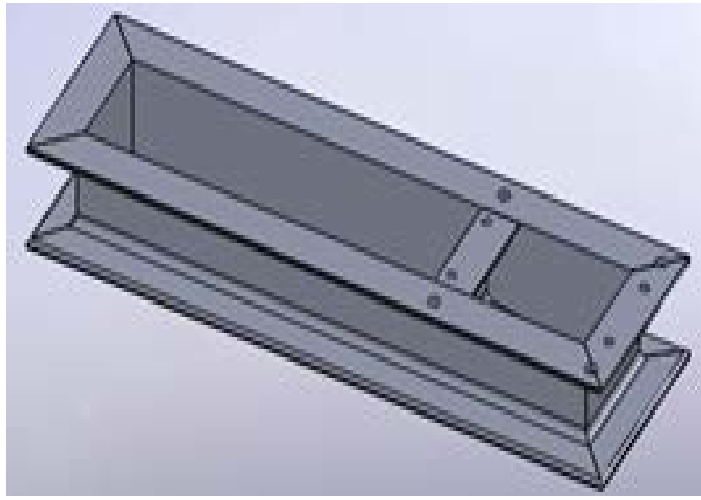
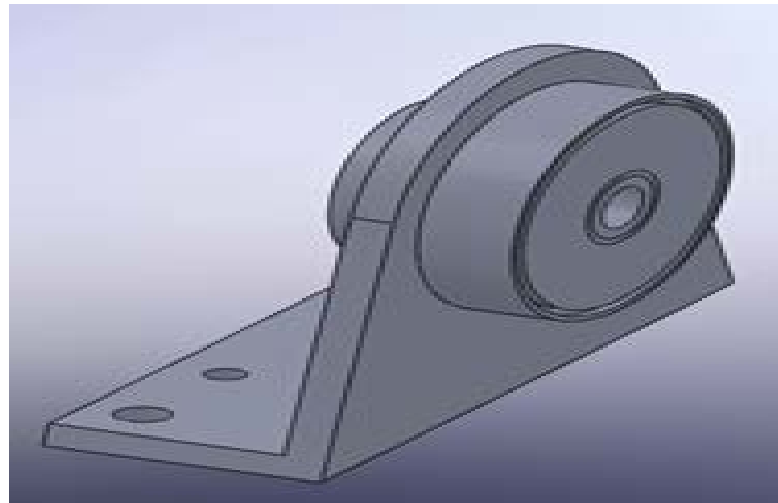

Figure 3.11: bed of the assembly,



3.12: outer casing

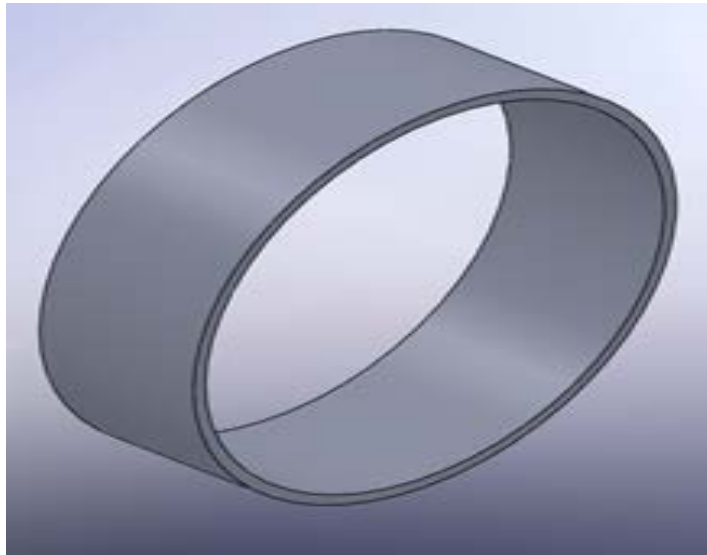
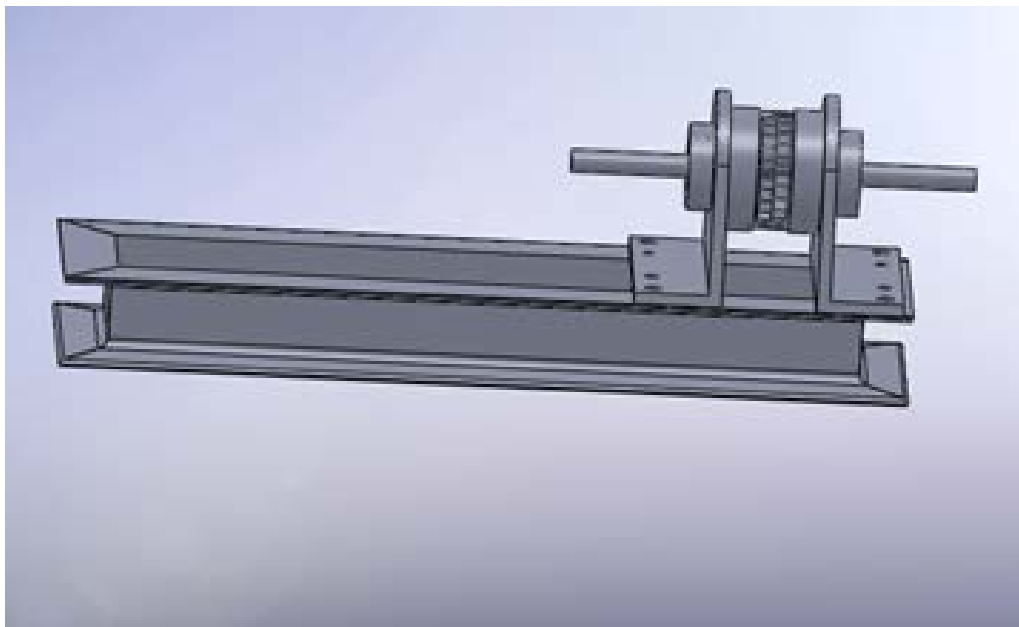

Figure3.13: glass of the fluid coupling



3.14.,final assembly

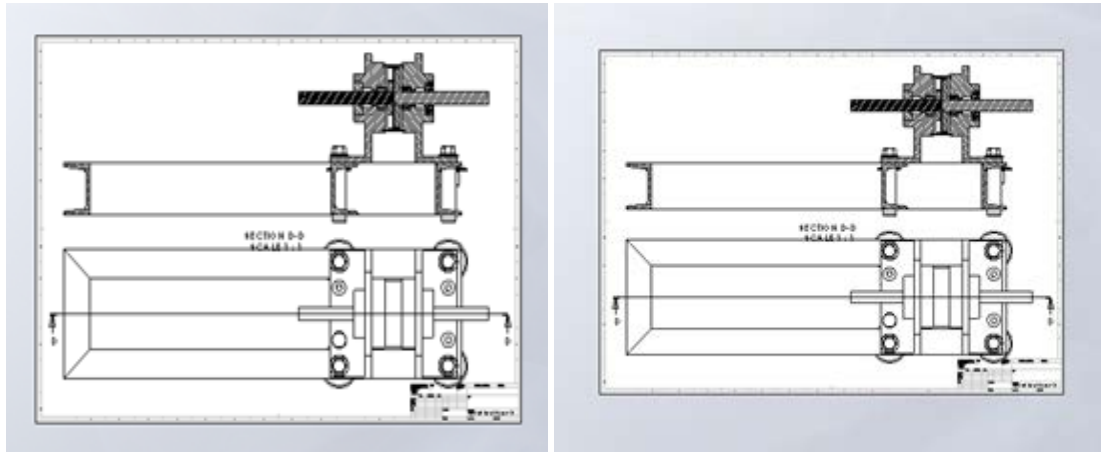

Figure 3.15,3.16:Front views of the final assembly

## CONCLUSIONS

- 1)Modelling of the modified fluid coupling was successfully done.
- 2)It was concluded that by minimising the gap between the driver and driven shaft the efficiency could be improved.
- 3)It is estimated that the efficiency about 95% could be achieved.
- 4)Based on the computational study this concept can be taken forward for analysis and experimental work.



## **BIBLIOGRAPHY**

1. Hydraulic Analysis of a Reversible Fluid Coupling Charles N. McKinnon California Institute of Technology, Pasadena, CA
2. Navier-Stokes analysis of the pump flow field of an automotive torque, converter, ASME J. Fluids Eng., 117, pp. 116–122. By, R.R., Kunz, R. and Lakshminarayana, B., 1995



3. Inverse Design of Impeller Blade of Centrifugal Pump with a Singularity Method- Wen-Guang LI,2011

4. Mathematical modelling of partially filled fluid coupling behaviour, A.M. Maqableh, 2011.