

Multifunctional Dynamic Voltage Restorer for Emergency Control in Distribution System

Geeta Awad¹, Suhas Jawale²

¹ M.E(EPS) Dept.of EEP Jawaharlal Nehru Engineering College,Aurangabad,M.S.

² Asst.Prof. Dept.of EEP Jawaharlal Nehru Engineering College,Aurangabad,M.S.

Abstract

Power quality has become a major area of concern in present era due to the increase in modern sensitive and sophisticated loads connected to the Distribution System. One of the major problems dealt in this paper is the voltage sag which is very severe for the industrial customers as it can cause malfunctioning of several sensitive electronic equipments. Dynamic Voltage Restorer (DVR) is a custom power device (CPD) that is connected in series with the network to improve voltage disturbance in the electrical system. This paper presents modeling, analysis and simulation of Dynamic Voltage Restorer (DVR) in MATLAB SIMULINK. This paper proposes PI controller and discrete PWM generator for control purpose of DVR. Simulation results are also presented to illustrate and understand the performance of DVR under various fault conditions such as three phase to ground, line to line fault etc. The results showed clearly the performance of the DVR in mitigating voltage sags.

Keywords: Custom Power Device (CPD), Dynamic Voltage Restorer (DVR), PI controller, Power Quality Pulse Width Modulation (PWM), Voltage Sag .

1. Introduction

The present-day electrical power system is AC i.e. electric power is generated, transmitted and distributed in the form of alternating current [2]. When the power is generated it possesses certain electrical properties that allow electrical system to function in their intended manner i.e. it can energizes all electrical equipment equally and satisfactorily. But power travels long distances through wires. Due to various pieces of equipments or due to any abnormal conditions in the network, the quality of the power changes and thus it becomes less suitable for any further application. Voltage magnitude is one of the major factors that determine the

quality of electrical power [10]. Hence it is necessary to improve the quality of power before it is used to energize any load. Though the transmission system and the distribution system are similar for man's circulatory system, in present scenario power quality directly related to distribution system. The reason behind is that distribution system locates at the end of the power system and is directly connected to the customer. The distribution system can be defined as that part of power system which distributes electrical power to the consumer for utilization [2]. Earlier the prime focus for power system reliability was on generation and transmission system but now a day's distribution system receives more attention. Because most of the electrical distribution network failures account for about 90% of the average customer interruptions and if any disturbance occur in the distribution system a huge amount of financial losses may happen with the consequent loss of productivity and competitiveness.

Some consumers require a level of power quality higher than the level provided by modern networks of electricity, hence many efforts have been under taken to fulfill consumer requirement. Initially for the improvement of the power quality and reliability of the system, Flexible AC Transmission System (FACTS) devices like static synchronous compensator (STATCOM), static synchronous series compensator (SSSC), interline power flow controller (IPFC), unified power flow controller (UPFC) etc. were used. FACTS devices are generally designed for the transmission system. But now-a-days these devices are modified to be used in distribution system and named as Custom Power Devices. Some of the widely used custom power devices are Distribution Static Synchronous Compensator (DSTATCOM), Dynamic Voltage Restorer (DVR), Active filter (AF), Unified power quality conditioner (UPQC) [4].

With the help of these devices power quality problems are reduced to a great extent. DVR is one of the most efficient and effective custom power devices due to its fast response, lower cost and smaller size [12]. Control Unit is the vital part of DVR and its main function is to detect the presence of voltage sags in the electrical system and to calculate the required amount of compensating voltage. The controlling of DVR is done by a Proportional Integral

(PI) Controller and a PWM Generator. PI controller is a type of feedback controller which operates the system to be controlled with a weighted sum of error. It generates the desired signal for the PWM generator to trigger the PWM inverter. The Phase lock loop (PLL) and dq0 transformation are also the basic components of DVR [7]. This paper, investigates the performance of DVR in improving the quality of power under three phase fault and line to line fault. The theory related to DVR operation and its different parts have been discussed in the next section. In section III Experimental details and simulation are discussed, and in section IV Analysis of the test results are done.

2. Configuration And Operation Of DVR

Among the power quality problems like sag, swell, harmonic, transients etc, voltage sag i.e. sudden voltage dip is the most severe disturbance in the power system, generally caused by faults. It last for duration ranging from 3 cycles to 30 cycles [10]. Starting of large induction motors can also result in voltage sag as it draws a large amount of current during starting. In order to mitigate this problem DVR is one of the efficient and effective custom power devices. DVR injects voltage into the system in order to compensate the voltage dip in the load side and maintains the load voltage at nominal magnitude. DVR is a solid state power electronic switching device which is connected in series to the power system. It comprises of the following components:

- [1] Energy storage device
- [2] Voltage source Inverter
- [3] Injection transformer
- [4] Control unit.

2.1. Principle Of Operation

DVR is connected in between the supply and the load as shown in the Fig 1. The main function of the DVR is to boost up the load side voltage so that load is free from any power disruption. Besides voltage sag compensation DVR also carry out other functions such as line voltage harmonic compensation, reduction of transients in voltage and fault current limitation.

- [1] Energy storage device: The purpose of the energy source is to supply the necessary energy to the VSI which will be converted to alternating quantity and fed to the injection transformer. Batteries are most commonly used and the capacity of the battery determine the duration of the sag which can be compensated by the DVR.
- [2] Voltage Source Inverter (VSI): A voltage source inverter is a power electronic device consisting of a switching device and a storage device such as battery. VSI can generate a sinusoidal voltage at any required magnitude, phase and frequency. VSI is used to

temporarily generate the part of the supply voltage that is missing. IGBT is the newer compact switching device that is used with VSI for DVR operation.

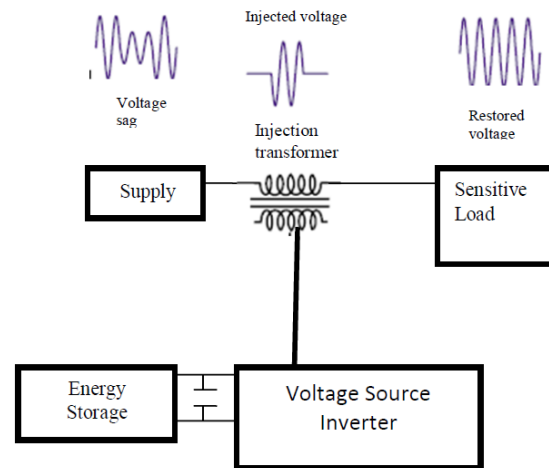

Fig. 1 Operation principle of DVR

[3] Injection transformer: It consists of two side voltage one is high voltage side and low voltage side. The high voltage side is normally connected in series with the distribution network while the power circuit of the DVR is connected to the low voltage side [13]. The DVR transfer the voltage which is required for the compensation from DC side of the inverter to the distribution network through the injection transformer. In this paper three single phase transformers are connected instead of a single three phase injection transformer. Each transformer is connected in series with each phase of the distribution feeder to couple the VSI (at low voltage level) to the higher distribution level. The transformer also helps in isolating the line from the DVR system.

[4] Control unit: A controller is used for proper operation of DVR system. DVR detects the presence of voltage sags and operates to mitigate the voltage dip. Pulse Width Modulation (PWM) control technique is applied for inverter switching so as to generate a three phase 50 Hz sinusoidal voltages at the load terminals. The magnitude of load voltage is compared with reference voltage and if any difference is there error signal will be generated as shown in the Fig.2. This error signal is the actuating signal which drives the PI controller and the final output signal which is obtained controls the pulses for the Inverter. PI controller is a feedback controller which controls the system depending on the error signal. In PI controller technique the proportional response can be obtained by multiplying the error with constant K_p (proportional gain). The integral response is proportional to both the magnitude of error and duration of error.

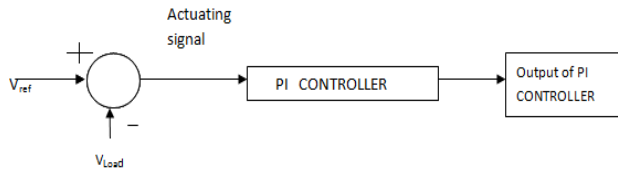

Fig.2 Schematic diagram of PI controller

In this study, the dq0 transformation or the Park's transformation is used for voltage calculation where the three phase stationary co-ordinate system is converted to the dq rotating quantity. The dq0 transformation technique is used to give the information of the depth (d) and phase shift (q) of voltage sag with start and end time. The V_0 , V_d and V_q are obtained as,

$$V_0 = (V_a + V_b + V_c) = 0$$

$$V_d = [V_a \sin \omega t + V_b \sin(\omega t -) + V_c \sin(\omega t +)]$$

$$V_q = [V_a \cos \omega t + V_b \cos(\omega t -) + V_c \cos(\omega t +)]$$

After conversion of the three phase voltage V_a , V_b and V_c into two constant voltages V_d and V_q the three phase system is simplified for voltage calculations. And the system can be easily controlled. The input of the DVR controller is taken from the output voltage measured by three-phase V-I measurement at load. This load voltage is then transformed into the dq term. Then if there is any voltage sag then the error signal is generated from the difference between the dq voltage and the reference voltage. The d reference is set to the rated voltage while the q reference is always set to zero. The gains such as K_p and K_i control the stability of the system. The output obtained from the PI controller is then again transformed back to V_{abc} before it is forwarded to the PWM generator. The PWM generator will generate 6 pulses to trigger the PWM inverter.

2.2. Theoretical Concept Of DVR

From the equivalent circuit of DVR given in Fig 3 the equation is found to be

$$V_{DVR} = V_{Load} + Z_{line} I_{load} - V_{source}$$

Where V_{Load} = Desired load Voltage
 Z_{line} = Line Impedance
 I_{load} = Load Current
 V_{source} = Supply voltage to the system

The line impedance Z_{line} depends on the fault level of the load. When a fault is occurred in the system the system voltage drops from any specific value then the DVR injects a series voltage i.e. V_{DVR} via the injection transformer so that the load voltage V_{LOAD} can be maintained at required level.

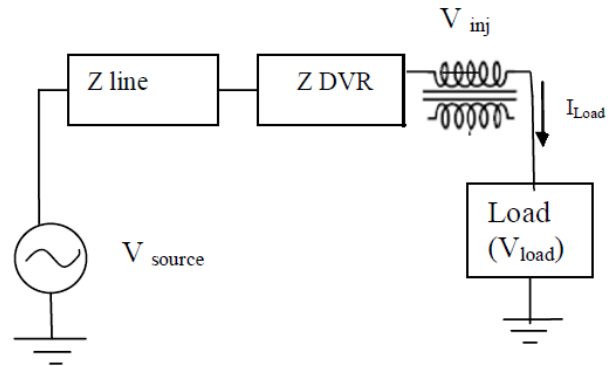

Fig3: equivalent circuit of DVR

3. Experimental Details And Simulation

The flow chart above depicts the method implemented in this paper. At the very beginning the magnitude of line voltage V_{line} and load voltage V_{load1} are measured. Both values are found to be equal. Then a fault is applied the magnitude of load voltage reduce suddenly to a great extent. The magnitude of the load voltage is measured again and it becomes V_{load2} . Then V_{load2} is compared with V_{load1} if V_{load2} is equal to V_{load1} . then DVR will not operate and no injection of voltage to the line.

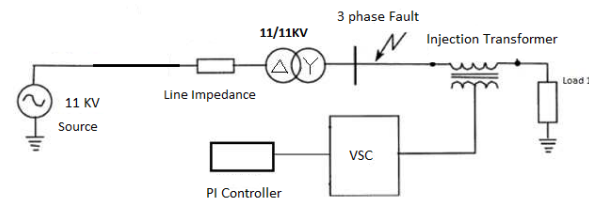

Fig 4: Block diagram of a DVR test model

But if V_{load2} is less than V_{load1} then DVR will inject the sag voltage V_{sag} and if V_{load2} is greater than V_{load1} DVR will not operate. After injection the new voltage will be $V_{load2} = V_{load2} + V_{sag}$. The DVR will inject voltage till it detects the difference between the load voltage before fault and after fault, i.e. the DVR will maintain the load voltage at nominal value until the fault is removed.

The components required for constructing the DVR test model is shown in the Fig 5 and Table1 shows the parameters of DVR test system consisting of 11KV, 50 Hz source feeding one distribution line through a two winding transformer.

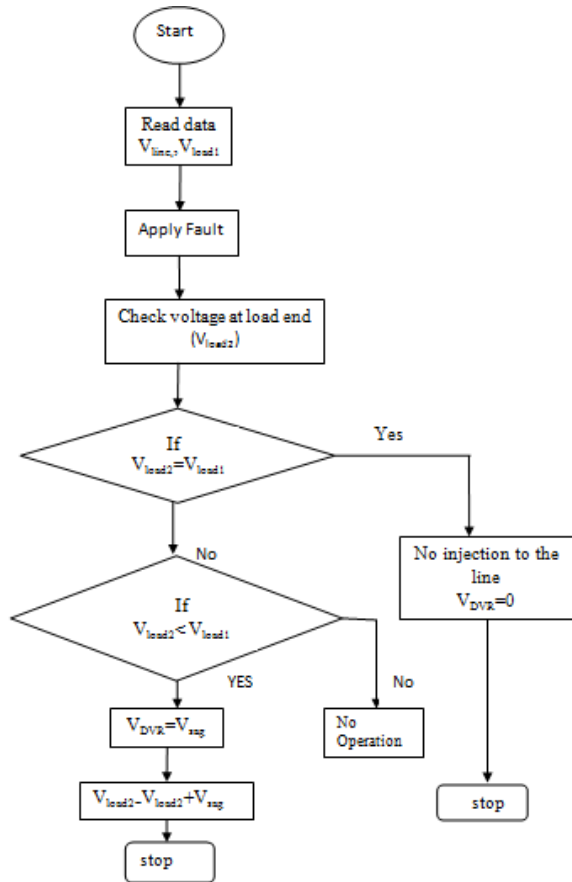

Fig.5 Flow chart of control scheme of DVR

Table 1
System Parameters

Sr. No	System Quantities	Standards
1	Source	3 phase, 11 KV, 50 Hz
2	Inverter Parameters	IGBT based, 3 arms, 6 pulse, Carrier frequency= 1080 Hz, Sample time = 50 μ s
3	PI Controller (2)	$K_{p1}=20, K_{i1}=154$, Sample time = 50 μ s $K_{p2}=25, K_{i2}=260$, Sample time = 50 μ s
4	RL load	Active power= 1KW, Inductive Reactive power= 500 VAR
5	Two winding transformer	$Y_d/\Delta, 11/11KV$

4. Results and Analysis Of The DVR Test Models

In this section the various results obtained after simulation are analysed and discussed. The simulink test model of DVR is shown in Fig. 6. The test system comprises of 11KV distribution network and the system has been examined under different fault conditions such as three phase to ground fault and line to line fault.

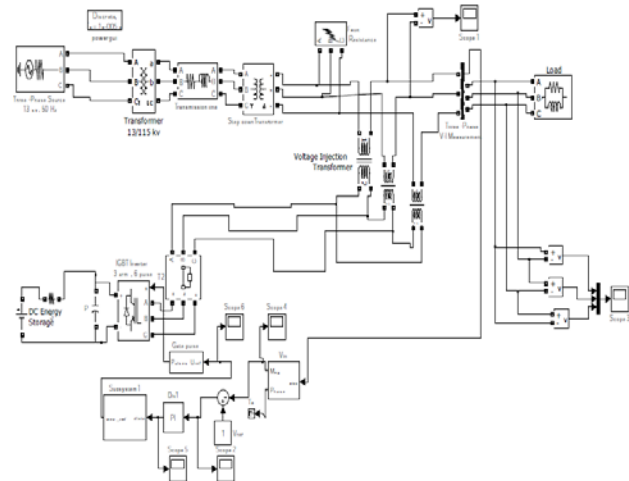

Fig.6 Test model of DVR

4.1. Test Results For Three Phase To Ground Fault

The simulation time for the model is taken as 1 sec. The first simulation was done without creating any fault at the network where supply is 11 KV with frequency 50 Hz. Fig 7 shows the waveforms of both input and load voltage without fault. Y- Axis shows the magnitude of voltage and X-axis shows the simulation time. Hence from the Fig 7 the input voltage is obtained to be 9000V and it is found that the magnitude of both the input and the load voltage is almost same.

The second simulation is done by applying three phase to ground fault with fault resistance of 0.66 Ω for a time duration of 100 ms i.e. from 0.1s to 0.2s and the ground resistance is 0.001 Ω . Supply is 11KV, with frequency 50 Hz. Waveforms for the load voltages (with and without compensation) are given below. Fig 8 shows the waveform of the input voltage with fault and without DVR. Even after the fault is created the input voltage remains almost same as before while load voltage experiences a huge change. Fig .9 shows the waveform of load voltage with fault and without DVR. With the application of the fault to the circuit the magnitude of the load voltage decreases at the fault period from 9000V to 800V. This voltage dip is needed to be compensated to get the desired voltage at the load.

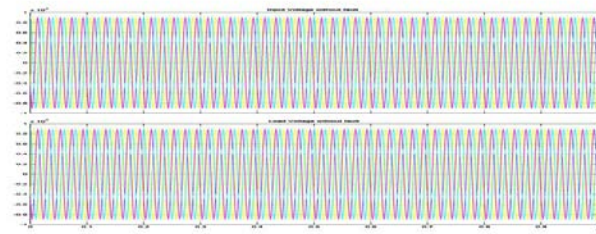

Fig 7 Waveform of input and load voltage without fault

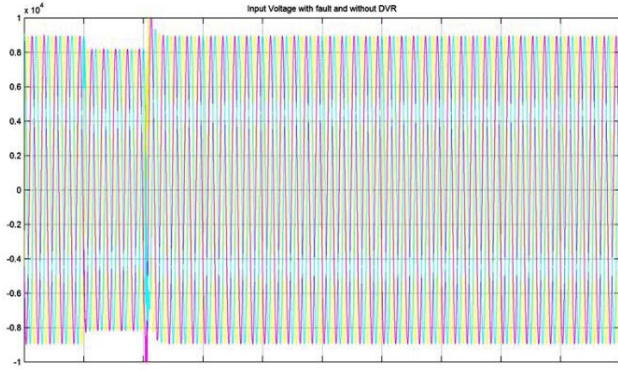

Fig 8 Waveform of input voltage with three phase fault and without DVR

The third simulation is carried out at the same scenario as above but the DVR is now introduced at the load side to compensate the voltage sag occurred due to the three phase fault applied. The waveform obtained from the test model is shown in Fig.10. It is clearly observed that the voltage waveform that is obtained after connection of DVR in series is almost similar to the supply voltage i.e. the DVR we installed is working efficiently.

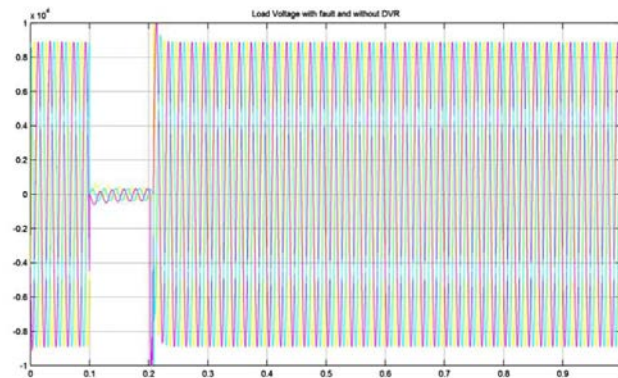

Fig 9 Waveforms of load voltage with three phase fault and without DVR

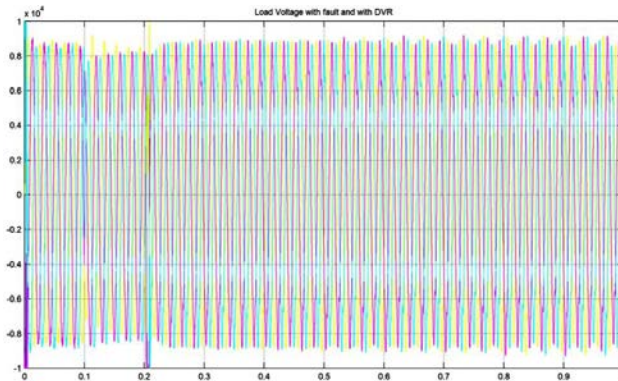

Fig 10 Waveforms of load voltage with three phase fault and with DVR

4.2. Test Results for Line to Line Fault

In case of line to line fault the fault resistance is taken as 0.66Ω , the fault is created for the period of 0.1sec to 0.2sec where the simulation time is for 1 sec. Supply is 11KV, 50 Hz. Fig.11 shows the input voltage with fault and without DVR which is obtained to be almost 9000V. Waveforms for the load voltage (with and without DVR compensation) are shown below. Fig.12 shows the load voltage with line to line fault and without connection of DVR. The fault is in phase A and B thus voltage dip is observed in Red and Yellow phase of the system. And its magnitude reduces to 5000V. While phase C i.e. voltage of Blue phase remains unaffected.

The next simulation is done with the same parameters but connecting the DVR at the load side. Fig.13 shows the waveform of the load voltage with DVR. Thus it is seen that voltage dip occurring in the two phases are compensated to a great extent.

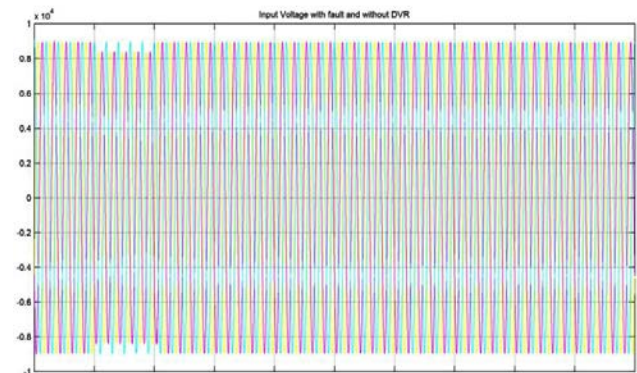

Fig.11 waveforms of input voltage with line to line fault without DVR

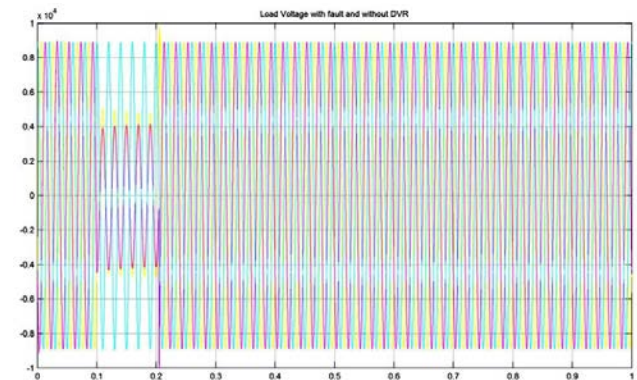

Fig.12 Waveforms of load voltage with line to line fault and without DVR

It is observed from the above figures that due to fault the load voltage reduce to a very low value. If we compare the waveforms of load voltage with and without DVR, we observed that when the DVR is in operation the voltage dip is compensated almost completely and the rms voltage at the sensitive point is maintained at normal condition.

The DVR is designed to supply the sag voltage until the fault is removed from the network.

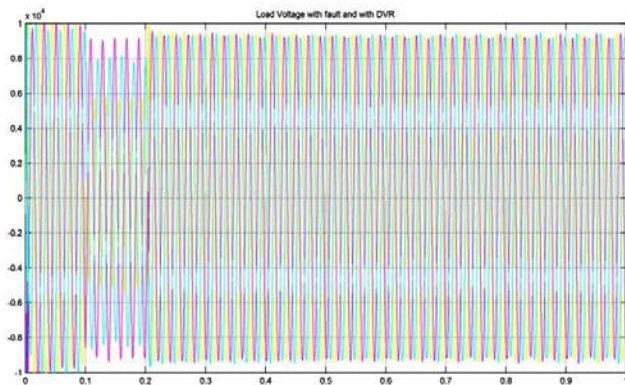

Fig. 13 Waveform of load voltage with line to line fault and with DVR

5. Conclusion

In this paper, the simulation of a DVR is done using MATLAB/SIMULINK software. Thus it became easier to construct the large distribution network and analyse the various result for two different types of faults. The controlling of DVR is done with the help of PI controller. The simulation results clearly showed the performance of the DVR in mitigating the voltage sag due to different fault conditions in distribution systems. DVR is one of the fast and effective custom power devices. DVR has shown the efficiency and effectiveness on voltage sag compensation hence it makes DVR to be an interesting power quality improvement Device. This has been proved through simulation and hardware implementation. From the analysis it is found that in case of a three phase fault almost 91% of compensation is done and in line to line fault voltage compensation took place for almost 44%. Besides PI controllers, other controllers like fuzzy controllers and adaptive PI fuzzy controllers can also be used in the DVR compensation technique.

References

[1] C. Sankaran "Power Quality", CRC Press 2002.
 [2] V.K Mehta, Rohit Mehta, Principle of Power System (revised edition, pp 300-309)
 [3] N.G. Hingorani, Flexible AC Transmission", IEEE Spectrum, vol. 30, pp. 40-44, 1993.
 [4] N.G. Hingorani and L Gyugyi, "Understanding FACTS – Concepts and Technology OF Flexible AC Transmission Systems", IEEE Press, New York, 2000.
 [5] N.G. Hingorani, "Introducing Custom Power", IEEE Spectrum, vol. 32, pp. 41- 48, 1995.

[6] Guide for Application of Power Electronics for Power Quality Improvement on Distribution Systems Rated 1 kV to 38 kV, IEEE P1409 Distribution Custom Power Task Force, 2003.
 [7] R. H. Salimin, M.S. A. Rahim, "Simulation Analysis of DVR performance for voltage sag mitigation", the 5th international power Engineering and Optimization Conference (PEOCO2011), 2011.
 [8] Michael D. Stump, Gerald J. Keane "The role, of custom power products in enhancing power quality at industrial facilities", Energy Management and Power Delivery, vol. 2, pp.507-517, International Conference 1998.
 [9] D. Daniel Sabin, Senior Member, IEEE, and Ambra Sannino, IEEE "A Summary of the Guide" Transmission and Distribution Conference and Exposition, IEEE PES, vol. 3, pp. 931-936, 2003.
 [10] M. H. Haque, "Compensation of Distribution System Voltage Sag by DVR and DSTATCOM", IEEE Porto Power Tech
 [11] Yash Pal, A. Swarup, Senior Member, IEEE, and Bhim Singh, Senior Member, IEEE "A Review of Compensating Type Custom Power Devices for Power Quality Improvement" IEEE Power India Conference, pp. 1-8, 2008.
 [12] Bingsen Wang, Giri Venkataramanan and Mahesh Illindala, "Operation and Control of a Dynamic.
 [13] Voltage Restorer Using. Transformer Coupled H-Bridge Converters", IEEE transactions on Power electronics, vol. 21, pp. 1053- 1061, July06.
 [14] Rosli Omar, N.A. Rahim and Marizan Slaiman, "Dynamic Voltage restorer Application for Power.
 [15] Quality improvement in Electrical Distribution System" Australian Journal of Basic and applied Sciences , pp 379-396, 2011
 [16] H.P. Tiwari and Sunil Kumar Gupta "Dynamic Voltage Restorer against Voltage Sag" International Journal of Innovation, Management and Technology vol. 1, no. 3, pp. 232-237, 2010.