

A photovoltaic power generation system with peak cut function

Sandip S. Rathod

M.E(EPS) Dept.of EEP
 Jawaharlal Nehru Engineering
 College,Aurangabad,M.S.

Pallavi G. Lone

Asst.Prof. Dept.of EEP
 Jawaharlal Nehru Engineering
 College,Aurangabad,M.S.

Bapu T. Deshmukh

Asso.Prof.&HOD Dept.of EEP
 Jawaharlal Nehru Engineering
 College,Aurangabad,M.S.

Abstract— this paper gives the basic idea behind the photovoltaic peak load power cutting. Generally the conventional photovoltaic power system uses converter, inverter and directly feed to load but in this system we utilize the storage batteries in between dc-dc converter and inverter through this type of arrangement we cut the peak power when generations is maximum than utilization in this way energy can be save. There is four possible power flow path can be possible through the bidirectional operation of dc-dc converter and inverter and through the charging and discharging of battery. This photovoltaic peak power cut system algorithm first selects the operational state by using differentiated charge and load information. With a simple structure to enable stopping in case of system failure, and operates depending on the selected state. Finally, the simulation and experimental results are presented to confirm the validity of the system.

Index Terms—photovoltaic system, photovoltaic peak power cut, Storage Battery, PV Conversion system.

I. INTRODUCTION

Nowadays, the interest in clean energy sources is a focus in countries across the world due to the environmental pollution caused by fossil fuels. PV, wind, fuel, and biomass are becoming promising sources of clean energy for the future. PV energy, among all of these new regeneration energies, has the advantage to minimize the costs of operation and maintenance differently from other new regeneration energies, and studies regarding PV cells and power converters have been actively performed for some time. An existing (PV-PCS) photovoltaic power conversion system use as energy source. The algorithm of the existing PV-PCS has a simple structure in that the energy generated from the PV is sent to the load. Therefore, the existing PV-PCS has the disadvantage that energy generation depends on the value of the PV radiation and temperature. Therefore, it is impossible to expect a reduction effect on the peak load but whenever the load is increase the system gets fail to fulfil the load demand that's why the necessity of peak power cutting and to know the time of maximum and minimum load. The above situation suggests that cutting the peak load is important, as well as determining the time and power that the distributed power supplies will generate considering the status of the load. This study handles the composition and control of the PV-PPC (Photovoltaic-Peak Power Cut) system that has a

peak load cutting function by using energy storage devices, and suggests the operation algorithm of the system. In addition, this study intends to verify feasibility through simulation and experimental case studies of the suggested operation algorithm.

II. PV-PPC SYSTEM

A. Conventional PV System

Fig. 1 represents a block diagram of the conventional PV power generating system as an existing energy source method. In this case, the time that the system can generate power varies depending on the amount of PV radiation, and it has a low use-level. However, since the users of the current PV power generating system endure a low use-level and perform operations accurately for the energy source, the system is operated without actual effect in respect to cutting the peak load, in spite of users' or consumers' actual burden of large costs. Fig. 2 represents the block diagram of the proposed PV power generating system with the peak power cutting function. This system is composed of a simple structure with a battery added, similar to the PV power generating system as an energy source, but the operation method of the system is different due to the addition of the battery. With storage of the PV energy and the system energy in a battery, the system has the peak power cutting function to discharge power when energy amounts requested by the load are greatly increased.

B. Configuration and control of PV-PPC

The PV-PPC system consists of a DC/DC converter, a battery as an energy storage device, and a DC/AC inverter. The PV-PPC system generates power or charges the battery by using PV energy, depending on the status of the amount of PV radiation and the load. The composition of the power circuits, the modeling, and the control of each part are described as follows.

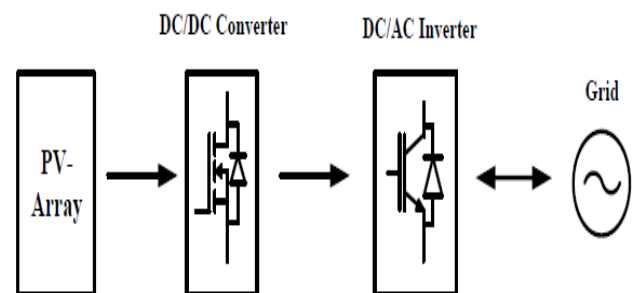

Fig. 1. Conventional PV system.

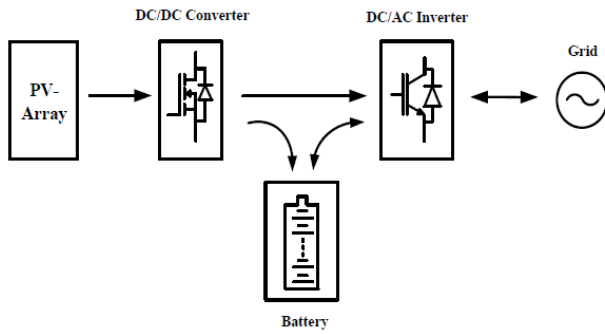

Fig. 2. Proposed PV system.

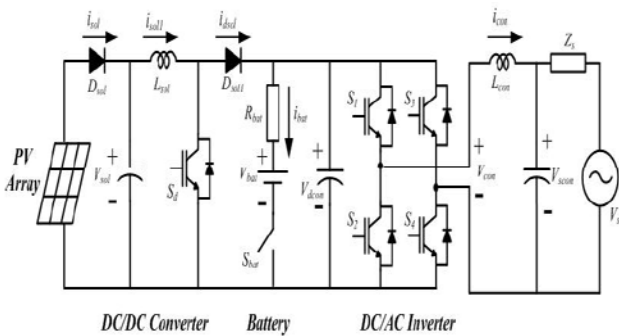

Fig. 3. The power circuit of the PV-PPC system

III. POWER CIRCUIT AND MODELLING OF PV-PPC SYSTEM

1. The PV-PPC system shown in Fig. 3 is composed of a DC/DC converter to boost the voltage of the PV, a battery to recharge or discharge the power from the PV or grid, and a DC/AC inverter interconnected to the grid. If applying Kirchhoff's voltage law to the power generation direction from the DC/AC inverter to the system, the voltage equations are expressed as Equations.(1) Through (9), where V_s is the grid voltage, V_{sol} is the PV voltage, V_{dcon} is the DC-link voltage, I_s is the grid current, I_{sol} is the PV current, and I_{bat} is the battery current.

$$V_{scon} = L_s \frac{di_s}{dt} + R_s I_s + V_s \quad (1)$$

$$C_{con} \frac{dV_{scon}}{dt} = I_{con} - I_s \quad (2)$$

$$L_{con} \frac{di_{con}}{dt} + V_{scon} = V_{con}(S_{con}(t) \cdot V_{dcon}) \quad (3)$$

Where,

$$S_{con}(t) = \begin{pmatrix} 1 & s1s4 \text{ on} \\ 1 & s2s3 \text{ on} \end{pmatrix}; \text{inverter switching,}$$

$$C_{cond} \frac{dV_{dcon}}{dt} = I_{sol2} - I_{cond} \quad (4)$$

$$I_{con} = S_{con}(t) \cdot I_{cond} \quad (5)$$

$$V_{sol} = L_{sol} \frac{di_{sol1}}{dt} + V_{sw} \quad (6)$$

$$V_{sw} = V_{dcon} * (1 - S_{dc}(t)) \quad (7)$$

Where,

$$S_{dc}(t) = \begin{pmatrix} 1 & sdc \text{ on} \\ 0 & sdc \text{ off} \end{pmatrix}$$

$$I_{sol2} = I_{sol1} * (1 - S_{dc}(t)) \quad (8)$$

$$C_{sol} \frac{dV_{sol}}{dt} = I_{sol} - I_{sol1} \quad (9)$$

By neglecting power loss, the instantaneous power balance equation can be expressed as Equations 10 through 12.

$$V_{scon} * I_{con} + \frac{1}{2} L_{con} \frac{di_{con}^2}{dt} = V_{con} i_{con} = -\frac{1}{2} C_{dcon} \frac{dV_{dcon}^2}{dt} + V_{con} I_{sol2} \quad (10)$$

$$V_{dcon} I_{sol2} = V_{sw} I_{sol1} = -\frac{1}{2} L_{sol} \frac{di_{sol1}^2}{dt} + V_{sol} I_{sol1} \quad (11)$$

$$V_{sol} I_{sol1} = -\frac{1}{2} C_{sol} \frac{dV_{sol}^2}{dt} + P_{sol} \quad (12)$$

Where,

$$P_{sol} = V_{sol} I_{sol}$$

2. Control of PV-PPC system

2.1 Control of the DC/DC converter

The DC/DC converter consists of an MPPT (Maximum Power Point Tracking) control to maximize the power generated in the PV, a voltage controller to control PV voltage ordered by the MPPT control, and a current controller to control the current of the PV, and the details are as follows. Fig. 4 represents the control composition diagram.

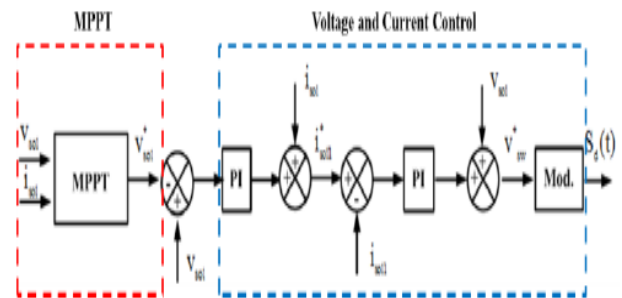

Fig.4 the control block diagram of DC/DC converter

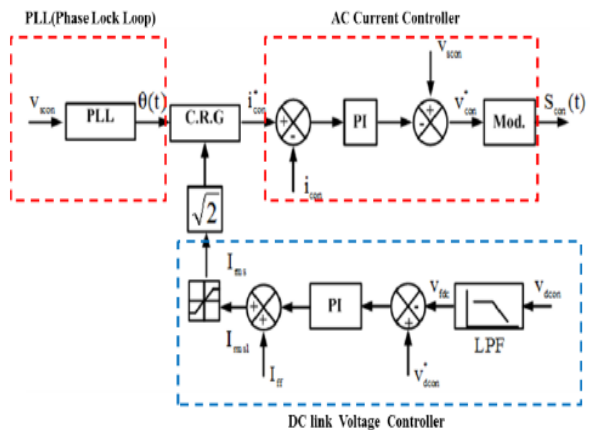

Fig.5. The control block of the DC/AC inverter

MPPT control: The MPPT control of the PV is a method to control the power generated in the PV to the maximum, which varies depending on the amount of PV radiation and temperature. This system uses a method of P&O (Perturbation and Observation) that makes the reference PV voltage increase the direction of the PV power.

Voltage and current controls of the converter: The voltage/current controller of the DC/DC converter consists of a double loop and controls the PV voltage generated from the MPPT control by using the DC/DC converter. Here, the PI controller is used as a voltage/current controller.

2) The Control of the DC/AC Inverter

The inverter control consists of the PLL (Phase Lock Loop) to identify the grid phase, DC-link voltage controller to control a constant DC-link voltage for balancing power, and current grid controller. The current controller transfers the PV power to the grid or grid power to the battery. A block diagram to control the DC/AC inverter is shown in Fig. 5.

PLL: The phase of the grid must be known in order to interconnect to the grid. The phase of the grid is determined by using the coordinate conversion of the DQ axis.

DC-link voltage & grid current controller: The DC-link voltage controller of the inverter transfers power generated in the PV to the grid, and controls the voltage of the DC-link as constant value. The DC-link voltage controller creates the reference value of the DC-link current. This is converted as the reference value of the grid current using the grid phase. The PI controller is used to control the voltage and current.

3. The operation algorithm of PV-PPC system

The PV-PPC (Photovoltaic–Peak Power Cut) system can function to store PV energy or store energy of the system with the battery connected to a DC-link, which is different from the existing PV power generating system that has been used so far. It also has the function to cut the peak load in response to the changes in the load and can reduce electrical charges. For the PV-PPC system with the battery connected, the possible power flow is shown in Fig. 6. The bidirectional operation of the inverter is also available.

The flow of energy, as shown in Fig. 6, represents the 1 storage of PV power in the battery, 2 direct delivery of PV power to the system, 3 generation of energy stored in the battery to the system, and 4 storage of power of the system in the battery.

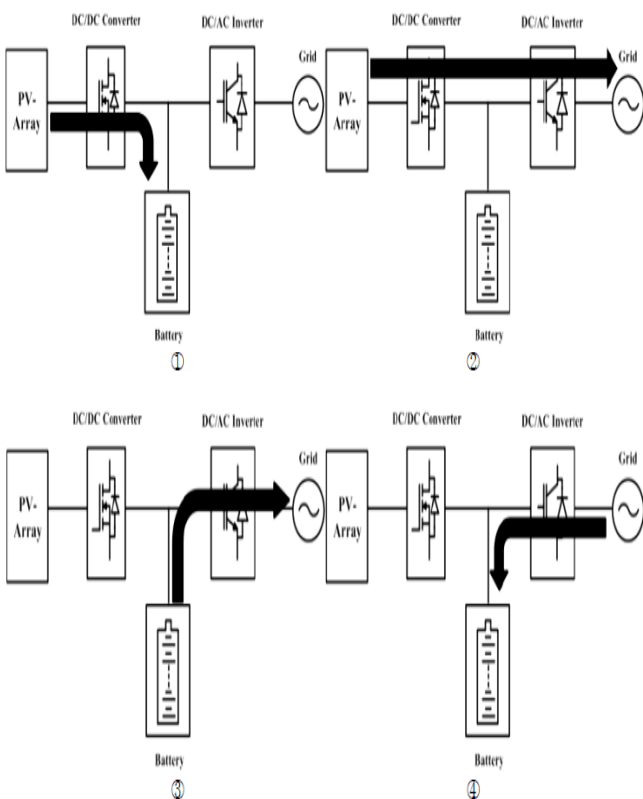

Fig.6 The possible power flow of the PV-PPC system

The suggested PV-PPC operation algorithm first calculates the date and time and selects the state by using differentiated charge information and load information, and is composed of a simple structure where the system stops in failure and operates depending on the selected state.

The suggested PV-PPC operational algorithm first calculates date and time, and then selects state by using different charge and load information. The operational algorithm is composed of a simple structure where the system stops in failure and operates depending on the selected state. Fig. 7 represents the block diagram of the operational algorithm.

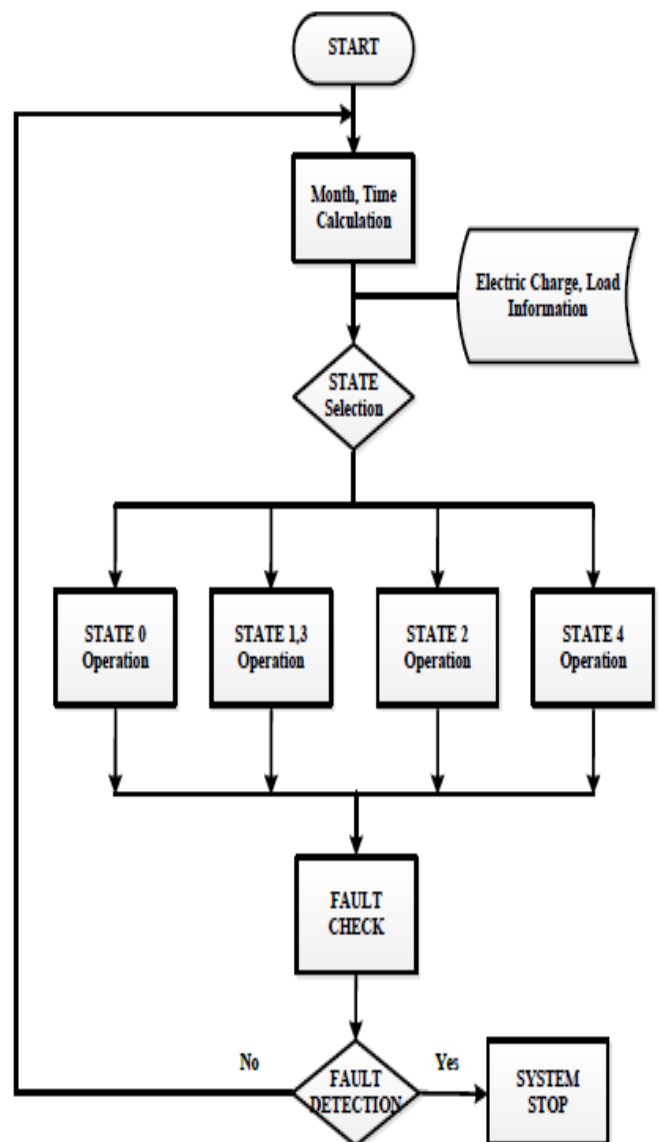

Fig. 7. The operational algorithm of the PV-PPC system.

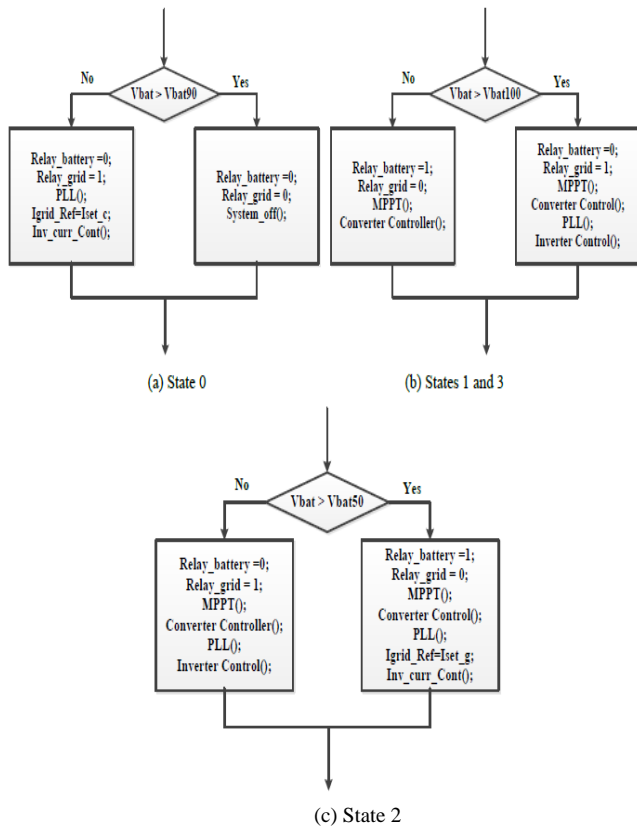

Fig.8. The detailed operation by state

Table 1. The explanation of Fig. 8

Notation	Explanation	Remark
Vbat	Battery voltage	Vbat50 : Voltage of 50% charge state Vbat90 : Voltage of 90% charge state Vbat100: voltage of 100% charge state
Relay_battery	Battery switch	0 : Off
Relay_grid	Grid switch	1 : On
PLL()	Function of PLL	Tracking the grid phase
Converter_Control()	Function of Converter control	This function consists of MPPT, voltage and current controller.
Inverter_Control()	Function of Inverter control	This function consists of voltage and current controller
System_off()	System off	System Stop
Igrid_Ref	Reference value of grid current	Iset_c : charging current Iset_g : generating current

STATE 0: This is the time to charge the battery by using cheap electricity at night. During this time, the relay of the grid and the battery must turn on to connect the system and the battery to the grid, and current control of the inverter must be performed by establishing current to recharge the battery from the system according to the voltage phase of the system. If the voltage of the battery becomes the reference value (90% of the complete recharge), operation STATE 0 is completed.

STATES 1 and 3: This is the time that PV power generation is possible, but the load is not peak load. During this time, the power generated by the PV charges the battery, and if the battery is completely charged, battery charging stops and the PV power is generated to the grid.

STATE 2: This is the peak load time. The power of the battery and the PV is generated toward the grid. In this state, the relays of both the battery and grid system remain on.

If the voltage of the battery drops below a constant value (50% of complete recharging voltage), the relay of the grid is turned off and the battery is charged by PV power.

STATE 4: There is no operation in this state.

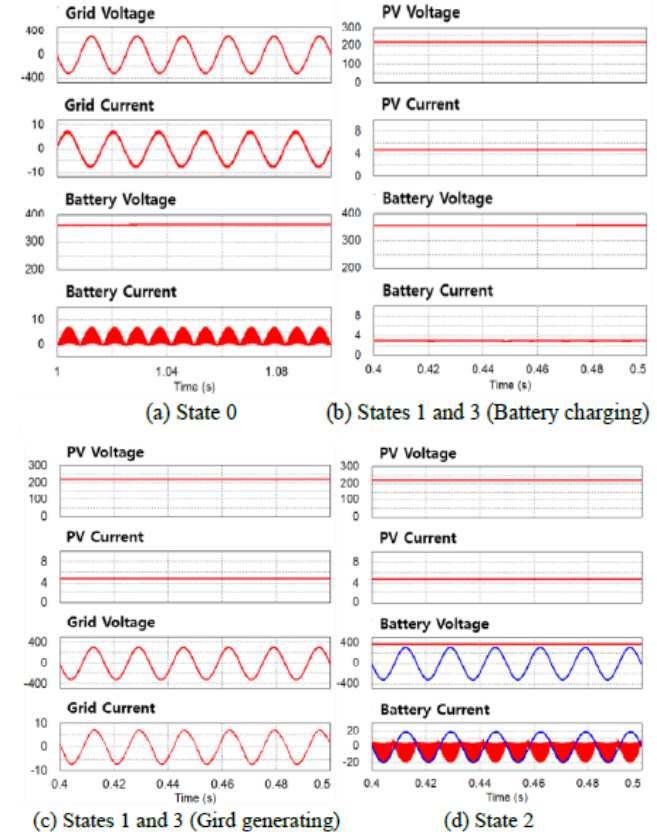
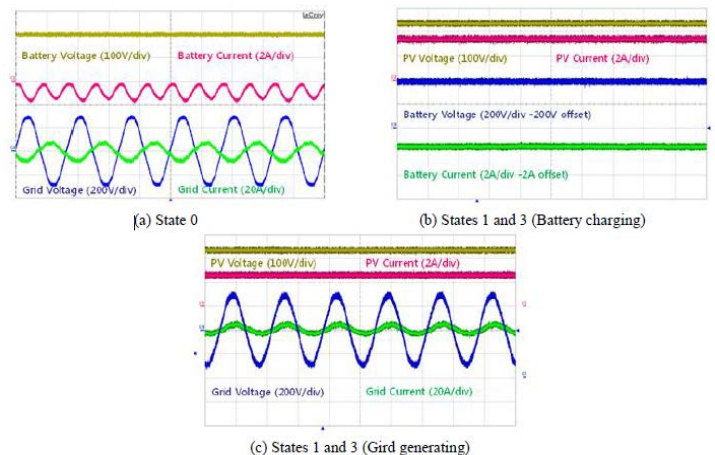

Fig.9 Simulation of PV-PPC system by state



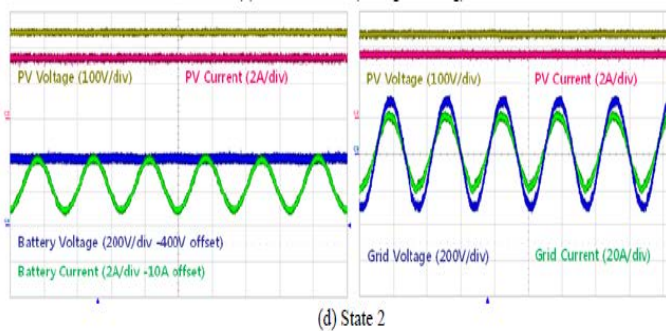

Fig.10. Experiment of the PV-PPC system by state

IV. SIMULATION AND EXPERIMENT

The simulation was performed by using the PSIM (9.0 PowerSim) to implement the operation of the PV-PPC system before the experiment. The simulated results are shown in Fig. 9. In Fig. 9 (a), the power of the PV (1100 W) is recharged in the battery, and Fig. 9 (b) shows the waveforms that the power of the PV is generating into the system. In the Fig. 9 (c), the PV and the battery are generating into the system. Fig. 9 (d) shows the recharging of the battery from the system by using the cheap time zone at night. Fig. 10 shows the experimental results which are similar to the simulation. In the experiment, the TMS320F28335 was used to control the system.

V. CONCLUSION

A PV-PPC power generation system with the peak load cutting function to reduce the peak load power effect of the power system is presented in this paper. Simulation analysis was performed using the PSIM software to validate the different operational modes of the power flow of the proposed PV-PPC system during the on-peak and off-peak periods. During on-peak operation, the power is managed to flow from the PV and the storage battery to help meet peak demands and reduce daily utility peak demands. During the periods of off-peak demand, the PV power can be stored in the system battery or fed to the utility grid. The feasibility of the proposed system has been verified practically through experimental results. Through the simulation and experimental results given in this paper, the system can effectively alleviate the peak load power hours efficiently which shows its potential to reduce utility electricity costs.

REFERENCES

[1] M.J.E Alam, student member, IEEE, K.M. Muttaqi, senior member, IEEE, and D. Sutanto, senior member, IEEE. Rooftop solar system and peak support by managing storage systems. *IEEE trans. power system*, VOL.28NO.4, Nonember 2013.
 [2] Shimizu T, Hirakata M, Kamezawa T, Watanabe H. Generation control circuit for photovoltaic modules. *IEEE Trans. Power Electronics*, 2001; 16(3):293-300.
 [3] Leyva R, Alonso C, Queinnec I. *et al.* MPPT of photovoltaic systems using extremum—seeking control. *IEEE Trans. Aerospace and Electronic Systems*, 2006; 42(1):249-258.
 [4] Kojabadi H M. A novel DSP-based current-controlled PWM strategy for single phase grid connected inverters. *IEEE Trans. Power Electronics*, Jul. 2006; 21:985-993.
 [5] Zhi LD. Improved direct power control of grid-connected DC/AC converters. *IEEE Trans. Power Electronics*, May 2009; 24:1280-1292.
 [6] Min BD. A novel grid-connected PV PCS with new high efficiency converter. *Journal of Power Electronics*, Oct. 2008; 8:309-316.

[7] Thangaprakash S. Unified MPPT control strategy for Z-source inverter based photovoltaic power conversion systems. *Journal of Power Electronics*, 2012; 12(1):172-180.
 [8] S.J.Chiang, K.T.Chang and C.Y.Yen. Residential photovoltaic energy storage system *IEEE Trans. Industrial Electronics*, VOL.45.NO.3, JUNE 1998
 [9] Wai RJ. High-performance stand-alone photovoltaic generation system. *IEEE Trans. Industrial Electronics*, 2008; 55(1):240-250.
 [10] Yanzhi Wang, student member, IEEE, Xue Lin, student member, IEEE, and Massoud Pedram, Fellow, IEEE. Adaptive control for Energy storage sydes in households with photovoltaic modules. *IEEE Trans. on smart grid*, VOL.5, NO.2, March 2014.
 [11] Choi W-Y, Choi J-Y. High-efficiency power conditioning system for grid-connected photovoltaic modules. *Journal of Power Electronics*, 2008; 11(4):561-567.
 [12] Kim YC, Jin L, Lee J, Choi J. Direct digital control of single-phase AC/DC PWM converter system. *Journal of Power Electronics*, 2010; 10(5):518-527.
 [13] Kim H, Parkhideh B, Bongers TD, Gao H. Reconfigurable solar converter: a single-stage power conversion PV-battery system. *IEEE Trans. Power Electronics*, 2013; 28(8):3788-3797.
 [14] Choi B-Y, Noh Y-S, Ji Y-H, et al. Battery-integrated power optimizer for PV-battery hybrid power generation system. In: *Proc. of IEEE Vehicle Power and Propulsion Conference (VPPC)*, 2012:1343-1348.
 [15] Nge CL, et al. PV with battery in smart grid paradigm: Price-based energy management system. In: *Proc. of 38th IEEE Photovoltaic Specialists Conference (PVSC)*, 2012:575-579



Sandip S. Rathod received the B. E. degree in Electrical Electronics and Power Engineering from Jawaharlal Nehru College of Engineering Aurangabad in 2013 and Diploma in Electrical Engineering from Government College of Polytechnic Washim (M.S) in 2010. His research interests are Photovoltaic Power Generation System.



P.G.Lone received the B. E. degree in Electrical Electronics and Power Engineering from Government College of Engineering Aurangabad in 2010, M. E. in Electric Machines & Drives from Government College of Engineering Aurangabad in 2012 And Her research interest are Electrical Machines and Renewable Energy.



B. T. Deshmukh received the B. E. degree in Electrical Electronics and Power Engineering from Government College of Engineering Aurangabad in 1989 and M. E. in Electrical Power System from Government College of Engineering Aurangabad in 1997. His research interests are Power Quality and Energy Management.